

THE WILLIAMSON AMPLIFIER

ARTICLES REPRINTED FROM "WIRELESS WORLD"



Three Shillings & Sixpence Net

Vortexion

Transformers and Chokes

for the

WILLIAMSON AMPLIFIER

NATIONAL PHYSICAL LABORATORY REPORT

ON TESTS OF TRANSFORMER (Marked : Lab : Output, Series II)

Tested for : Vortexion Ltd., 257/263 The Broadway, London, S.W.19.

The series resistance and inductance of the primary winding with the secondary winding open-circuited, was measured at 50 cycles per second with 5 and 20 volts applied. The room temperature was 19°C. The results are given in Table I.

TABLE I

**Primary Resistance and Inductance
at 50 c/s.**

Voltage	Resistance (Ω)	Inductance (H)
5	4 700	95
20	7 900	142

The series resistance and inductance of the primary winding with the secondary winding short-circuited, and of half the primary winding with the other half short-circuited were measured at 1,000 cycles per second. About 10 volts were applied. The results are given in Table II.

TABLE II

Resistance and Inductance at 1,000 c/s

Connections	Resistance (Ω)	Inductance (mH)
Primary, Secondary shorted.	495	5.3
Half Primary, Half Primary shorted.	222	5.5

Date : 2nd June, 1951. Reference : E.475.100.

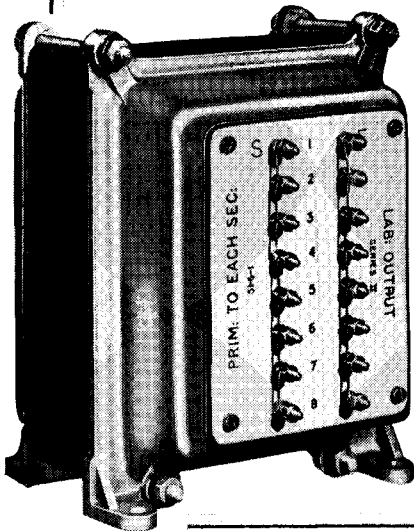

This Laboratory Model Transformer Series II easily permits 6 db more feedback with complete stability than the maximum of our Series I which Mr. D. T. N. Williamson described.

PRICES

Series II Output Transformers as above	£7. 7. 0
Series I Output Transformers	£6. 6. 0
Mains Transformers	£4. 4. 0
CHOKES 10 12H, 150 mA	£1. 11. 6
CHOKES 30/H, 20 mA	£2. 0. 6

Please write for Catalogue WA/5

VORTEXION LTD.

257-263, THE BROADWAY, WIMBLEDON, LONDON, S.W.19

Telephones : LIBerty 2814 and 6242-3 Telegrams : "VORTEXION, WIMBLE, LONDON"

The Williamson Amplifier

A Collection of Articles,
reprinted from "Wireless World," on
"Design for a High-quality Amplifier"

By

D. T. N. WILLIAMSON

*(formerly of the M.O. Valve Company, now
with Ferranti Research Laboratories)*

Published for

Wireless World

LONDON : ILIFFE & SONS, LTD.

IT'S YOUR CHOICE

If the components are below standard, there's not much justification for expecting first-class results. It has been our experience and that of many satisfied customers that in building the Williamson Amplifier it definitely pays to use the best components. All items supplied are new and guaranteed.

SPECIAL

WILLIAMSON AMPLIFIER (Fig. 1)

TWO COMPLETE KITS OF ALL SPECIFIED PARTS EACH INCLUDING PARTRIDGE OUTPUT TRANSFORMER — DRILLED STEEL CHASSIS — MARCONI/OSRAM/COSSOR VALVES — G.E.C. AND T.C.C. CONDENSERS THROUGHOUT.

With **ELLISON MAINS TRANSFORMER AND CHOKES** 19 Gns.

With **PARTRIDGE MAINS TRANSFORMER AND CHOKES** 21 Gns.

CARRIAGE IN U.K. 7s. 6d.

PACKING 10/- RETURNABLE.

MAIN AMPLIFIER (FIG. 1)

PARTRIDGE OUTPUT TRANSFORMERS: 1.7, 0.95 or 3.6 ohm
Secondaries: Wire ended £6/1/-; Tag Board £6/16/6; Potted £7/5/3.

MAINS TRANSFORMERS:

PARTRIDGE 74/- ELLISON 56/3

SMOOTHING CHOKES:

PARTRIDGE 25 H. 60 mA. 20/9 13 H. 200 mA. 40/3

ELLISON 30 H. 20 mA. 15/8 10 H. 150 mA. 23/3

VALVES:

MARCONI OSRAM KT66 MATCHED PAIRS 50/2

MARCONI OSRAM L63 14/4 COSSOR 53KU 21/6

RESISTORS. A full range is available, including:

22K 1 watt Matched, Pr. 2/- 47K 2 watt Matched, Pr. 3/-

150 ohm 3 watt 1/6

CHASSIS:

STEEL DRILLED FOR KITS 27/6.

STEEL 17in. x 10in. x 3in. UNDRILLED 12/6.

ALUMINIUM 17in. x 10in. x 2½in. UNDRILLED 12/6.

CONDENSERS T.C.C.:

2-8 mfd. 600 v. ea. 15/- 1-8 + 8 mfd. 450 v. ea. 7/6

2-.05 mfd. 350 v. " 2/- 1-200 pfd. 350 v. " 1/2

1-8 mfd. 500 v. " 6/6 2-.25 mfd. 350 v. " 2/8

POTENTIOMETERS:

2-100 ohms COLVERN ea. 7/2.

PRE-AMPLIFIER (FIGS. 13 and 27)

RESISTORS—See Below.

CONDENSERS, T.C.C. AND DUBILIER:

1-.5 mfd. 350 v. ea. 3/- 1-16 mfd. 450 v. ea. 5/-

1-100 pfd. 350 v. " 1/6 1-50 mfd. 12 v. " 2/9

1-4000 pf. 10% " 2/6 1-.05 mfd. 500 v. " 2/1

VALVE: 1 EF37A " 25/1

PRE-AMP WITH HIGH PASS FILTER (FIGS. 15 and 29)

RESISTORS—See Below.

CONDENSERS, T.C.C. AND DUBILIER:

2-.5 mfd. 350 v. ea. 3/- 2-16 mfd. 450 v. " 5/-

1-4000 pf. " 2/6 1-.01 mfd. ±2% " 6/3

2-5000 pf. Matched " 3/6 1-5 mfd. 500 v. " 3/10

2-50 mfd. 12 v. " 2/9 1-.02 mfd. 350 v. " 1/9

1-100 pfd. 350 v. " 1/6 1-.25 mfd. 500 v. " 2/10

VALVES: 3-EF37A " 25/1

FADING CONTROL (FIG. 18)

RESISTORS—See Below.

CONDENSERS, T.C.C. AND DUBILIER:

1-4 mfd. 250 v. 17/2 1-.1 mfd. 350 v. 2/3

1-2 mfd. 350 v. 8/6

tone compensation and filter unit (FIG. 19)

RESISTORS—See Below.

CONDENSERS, T.C.C. AND DUBILIER:

3-50 mfd. 12 v. ea. 2/9 1-25 mfd. 500 v. ea. 2/10

1-.01 mfd. 350 v. " 1/8 1-1000 pf. " 1/6

50/500 pf. Silver Mica ±5% ea. 1/4-1/7; 1% ea. 1/6-2/3.

2-8 mfd. 450 v. " 3/6 1-150 pf. Trimmer " 1/6

3-.05 mfd. 350 v. " 2/- 2-16 mfd. 500 v. " 6/-

SWITCHES:

1-1 pole, 5 way, 5 bank, .. 17/6 1-S.P.D.T. " 3/8

1-D.P.D.T. " 3/11

MAINS TRANSFORMER:

325 v. 45 mA. etc.: PARTRIDGE 42/-; ELLISON 32/3.

SMOOTHING CHOKE—PARTRIDGE 75H. 25 mA. 20/9.

VALVES: 3-EF37A, ea., 25/1; 1-6X5, 15/1.

RADIO FEEDER UNIT (FIG. 20)

(a) VARIABLE TUNING MODEL

RESISTORS: See Below.

CONDENSERS:

3-1 mfd. 350 v. ea. 2/3 2-100 pf. ea. 1/4

1-2 Gang 500 pf. " 9/6 1-16 mfd. 450 v. " 5/-

COILS—ATKINS HIGH "Q" — 1 each AL2/R, AL2/W ea. 4/-.

DIALS—JB "AIRPLANE" 13/-; or "SQUAREPLANE" 12/9.

VALVES: 1-EF39, 18/8; 1-EF37A, 25/1.

(b) PRE-SET TUNING MODELS

SWITCH 2 wafers, 9/6.

COILS—ATKINS HIGH "Q", ea., 4/-.

TRIMMERS, ea., 1/6 to 2/3.

RESISTORS

COMPOSITION: ¼ and ½ watt 20%, 6d. each.

¼ and ½ watt 10%, 8d. each; 1 watt 1/- each

HIGH STABILITY ¼ and ½ watt 1% and 2%, 2/- each.

¼ watt 5%, 1/- each; ½ watt 5%, 1/3 each.

NOTE: PRICES AS RULING AT DATE OF PURCHASE.

Send for Detailed Price List, Post Free. Prompt Delivery. Terms C.W.O. or C.O.D. Postage Extra

OVERSEAS ENQUIRIES INVITED.

110v. WINDINGS AND TROPICALISED COMPONENTS AVAILABLE.

TELE-RADIO (1943) LIMITED

177a & 189, EDGWARE ROAD, LONDON, W.2

Tel: PAD 6116
PAD 5606

Shop Hours: Monday—Saturday 9 a.m.—6 p.m.
Thursday 9 a.m.—1 p.m.

CONTENTS

	<i>Page</i>
<i>Introduction</i>	5
<i>Basic Requirements:</i>	7
<i>Alternative Specifications</i>	
(April 1947)	
<i>Details of Chosen Circuit and Its Performance</i>	11
(May 1947)	
 NEW VERSION	
<i>Design Data:</i>	14
<i>Modifications: Further Notes</i>	
(August 1949)	
<i>Design of Tone Controls and Auxiliary Gramophone Circuits</i>	20
(October and November 1949)	
<i>Design for a Radio Feeder Unit</i>	30
(December 1949)	
<i>Replies to Queries Raised by Constructors</i>	34
(January 1950)	
<i>Modifications for High-impedance Pickups and Long-playing Records</i>	35
(May 1952)	

The journal for all radio technicians

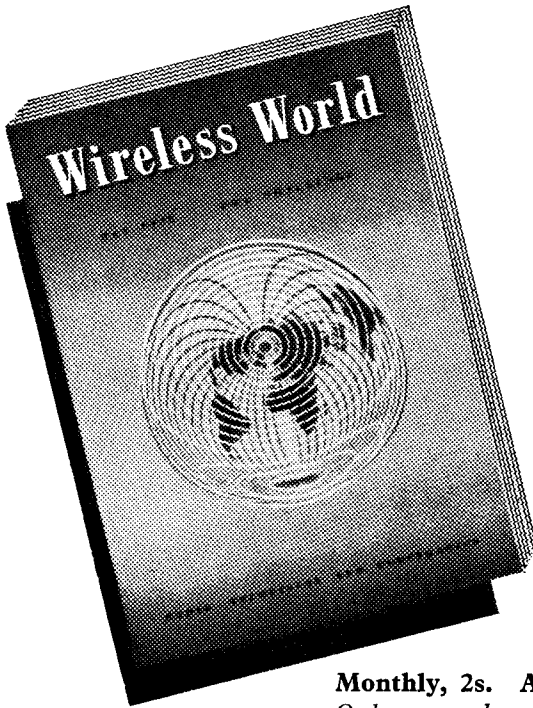

WIRELESS WORLD is Britain's leading technical journal devoted to radio, television and electronics — its pages providing a complete and accurate survey of the newest British techniques in design and manufacture.

Articles of a high standard cover every phase of radio and allied technical practice, as well as the wider aspects of international radio. Theoretical articles by recognized experts deal with new developments, while design data and circuits for every application are published regularly.

Monthly, 2s. Annual Subscription, £1 7s.
*Order a regular copy of WIRELESS WORLD from
your newsagent—to-day.*

The journal for all advanced workers

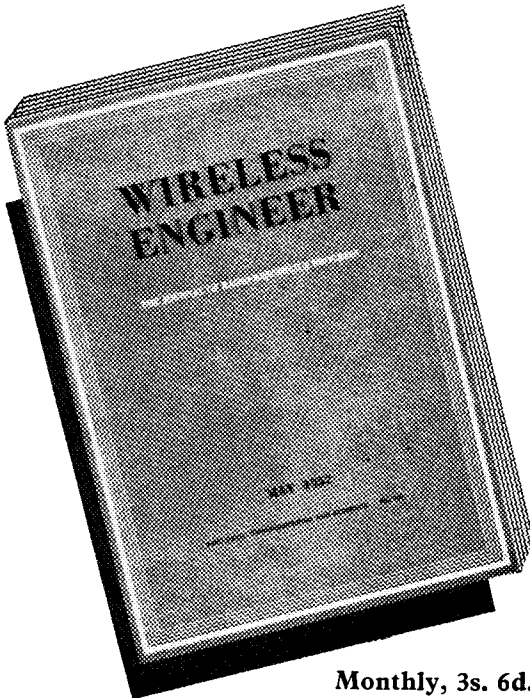

WIRELESS ENGINEER — produced for research engineers, designers and students in radio, television and electronics — is the international source of information for advanced workers; the journal publishes only original work. It is served by an Editorial Advisory Board composed of representatives from the National Physical Laboratory and the British Post Office, and publishes Abstracts and References compiled by the Radio Research Organization of the Department of Scientific and Industrial Research.

Monthly, 3s. 6d. Annual Subscription, £2 4s. 6d.
*Your newsagent will be glad to supply a regular
copy of WIRELESS ENGINEER. See him to-day!*

Introduction

Introduced by *Wireless World* in 1947 as merely one of a series of amplifier designs, the "Williamson" has for several years been widely accepted as the standard of design and performance wherever amplifiers and sound reproduction are discussed. Descriptions of it have been published in all the principal countries of the world, and so there are reasonable grounds for assuming that its widespread reputation is based solely on its qualities.

This booklet includes all the articles written by D. T. N. Williamson on the amplifier. Both the 1947 and 1949 versions are reprinted, as the alternative output transformer ratios cover a wide range of requirements. Modifications and additions include pre-amplifier circuits and an r.f. unit, with recently published information on adaptation to high-impedance pickups and correction for $33\frac{1}{3}$ r.p.m. records.

We would stress the importance, if the full potentialities of the amplifier are to be realized, of following the author's recommendations in detail. Even in the U.S.A., where several modified versions have been described, many users adhere to the designer's exact specification with the original valve types. It is not the circuit alone, but the properties of the valves and such components as the output transformer, together with the welding of theory and practice into a rational layout, which produce the results.

Editor, *Wireless World*.



POTTED COMPOUND FILLED TRANSFORMERS & CHOKES



WODEN Potted components are in constant demand for the
WILLIAMSON AMPLIFIER AND PRE-AMPLIFIER.

note the advantages

- Made to the author's exact specification.
- Smart appearance and uniform layout.
- Absolute Reliability.

SEND FOR FURTHER PARTICULARS AND COMPLETE CATALOGUE.

WODEN TRANSFORMER CO. LTD

MOXLEY ROAD BILSTON STAFFS

PHONE: BILSTON 41959

J.T.L.

Basic Design Requirements: Alternative Specifications

RECENT improvements in the field of commercial sound recording have made practicable the reproduction of a wider range of frequencies than hitherto. The useful range of shellac pressings has been extended from the limited 50–8,000 c/s which, with certain notable exceptions, has been standard from 1930 until the present, to a range of some 20–15,000 c/s. This increase in the frequency range has been accompanied by an overall reduction in distortion and the absence of peaks, and by the recording of a larger volume range, which combine to make possible a standard of reproduction not previously attainable from disc recordings. Further improvements, notably the substitution of low-noise plastic material for the present shellac composition, are likely to provide still further enhanced performance.

The resumption of the television service with its first-class sound quality, and the possible extension of u.h.f. high-quality transmissions, increase the available sources of high-quality sound.

Full utilization of these recordings and transmissions demands reproducing equipment with a standard of performance higher than that which has served in the past. Extension of the frequency range, involving the presence of large-amplitude low-frequency signals, gives greater likelihood of intermodulation distortion in the reproducing system, whilst the enhanced treble response makes this type of distortion more readily detectable and undesirable.

Reproduction of sound by electrical means involves the amplification of an electrical waveform which should be an exact counterpart of the air pressure waveform which constitutes the sound. The purpose of the amplifier is to produce an exact replica of the electrical input voltage waveform at a power level suitable for the

operation of the loudspeaker. This in turn reconverts the electrical waveform into a corresponding sound pressure waveform, which in an ideal system would be a replica of the original.

The performance of an amplifier intended to reproduce a given waveform is usually stated in terms of its ability to reproduce accurately the frequency components of a mythical Fourier analysis of the waveform. While this method is convenient and indeed corresponds to the manner in which the mechanism of the ear analyses sound pressure waveforms into component frequencies and thereby transmits intelligence to the brain, the fact that the function of the system is to reproduce a waveform and not a band of frequencies should not be neglected. Sounds of a transient nature having identical frequency contents may yet be very different in character, the discrepancy being in the phase relationship of the component frequencies.

The requirements of such an amplifier may be listed as:—

(1) Negligible non-linear distortion up to the maximum rated output. (The term “non-linear distortion” includes the production of undesired harmonic frequencies and the intermodulation of component frequencies of the sound wave.) This requires that the dynamic output/input characteristic be linear within close limits up to maximum output at all frequencies within the audible range.

(2) (a) Linear frequency response within the audible frequency spectrum of 10–20,000 c/s.

(b) Constant power handling capacity for negligible non-linear distortion at any frequency within the audible frequency spectrum.

This requirement is less stringent at the high-frequency end of the spectrum, but should the maximum power output/frequency response at either end of the

spectrum (but especially, at the low-frequency end) be substantially less than that at medium frequencies, filters must be arranged to reduce the level of these frequencies *before* they reach the amplifier as otherwise severe intermodulation will occur. This is especially noticeable during the reproduction of an organ on incorrectly designed equipment where pedal notes of the order of 16–20 c/s cause bad distortion, even though they may be inaudible in the sound output.

(3) Negligible phase shift within the audible range. Although the phase relationship between the component frequencies of a complex steady-state sound does not appear to affect the audible quality of the sound, the same is not true of sounds of a transient nature, the quality of which may be profoundly altered by disturbance of the phase relationship between component frequencies.

(4) Good transient response. In addition to low phase and frequency distortion, other factors which are essential for the accurate reproduction of transient waveforms are the elimination of changes in effective gain due to current and voltage cut-off in any stages, the utmost care in the design of iron-cored components, and the reduction of the number of such components to a minimum.

Changes in effective gain during “low-frequency” transients occur in amplifiers with output stages of the self-biased Class AB type, causing serious distortion which is not revealed by steady-state measurements. The transient causes the current in the output stage to rise, and this is followed, at a rate determined by the time constant of the biasing network, by a rise in bias voltage which alters the effective gain of the amplifier.

(5) Low output resistance. This requirement is concerned with the attainment of good

The Williamson Amplifier

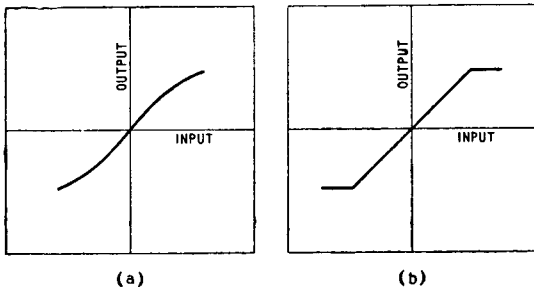

Fig. 1. Output/input characteristics (a) without feedback (b) with negative feedback.

frequency and transient response from the loudspeaker system by ensuring that it has adequate electrical damping. The cone movement of a moving-coil loudspeaker is restricted by air loading, suspension stiffness and resistance, and electro-magnetic damping. In the case of a baffle-loaded loudspeaker, the efficiency is rarely higher than 5-10 per cent, and the air loading, which determines the radiation, is not high. In order to avoid a high bass-resonance frequency, the suspension stiffness in a high-grade loudspeaker is kept low, and obviously the power loss in such a suspension cannot be large. Electro-magnetic damping is therefore important in controlling the motion of the cone. This effect is proportional to the current which can be generated in the coil circuit, and is therefore proportional to the total resistance of the circuit. Maximum damping will be achieved when the coil is effectively short-circuited, hence the output resistance of the amplifier should be much lower than the coil impedance.

(6) Adequate power reserve. The realistic reproduction of orchestral music in an average room requires peak power capabilities of the order of 15-20 watts when the electro-acoustic transducer is a baffle-loaded moving-coil loudspeaker system of normal efficiency. The use of horn-loaded loudspeakers may reduce the power requirement to the region of 10 watts.

The Output Stage

An output of the order of 15-20 watts may be obtained in one of three ways, namely, push-pull triodes, push-pull triodes with negative feedback, or push-pull tetrodes with negative feedback.

The salient features of these methods are of interest.

Push-pull triode valves without the refinement of negative feedback form the mainstay of present-day high-fidelity equipment. A stage of this type has a number of dis-

advantages. With reasonable efficiency in the power stage such an arrangement cannot be made to introduce non-linearity to an extent less than that represented by about 2-3 per cent harmonic distortion. The output/input characteristic of such a stage is a gradual curve as in Fig. 1 (a). With this type of characteristic distortion will be introduced at all signal levels and intermodulation of the component signal frequencies will occur at all levels. The intermodulation with such a characteristic is very considerable and is responsible for the harshness and "mushiness" which characterizes amplifiers of this type. In addition, further non-linearity and considerable intermodulation will be introduced by the output transformer core.

If the load impedance is chosen to give maximum output the load impedance/output resistance ratio of the amplifier will be about 2, which is insufficient for good loudspeaker damping.

It is difficult to produce an adequate frequency response characteristic in a multi-stage amplifier of this type as the effect of multiple valve capacitances and the output transformer primary and leakage inductances becomes serious at the ends of the a.f. spectrum.

The application of negative feedback to push-pull triodes results in the more or less complete solution of the disadvantages outlined above. Feedback should be applied over the whole amplifier, from the output transformer secondary to the initial stage as this method corrects distortion introduced by the output transformer and makes no additional demands upon the output capabilities of any stage of the amplifier.

The functions of negative feedback are :-

(a) To improve the linearity of the amplifier, and output transformer.

(b) To improve the frequency response of the amplifier and output transformer.

(c) To reduce the phase shift in the amplifier and output transformer within the audible frequency range.

(d) To improve the low-frequency characteristics of the output transformer, particularly defects due to the non-linear relation between flux and magnetizing force.

(e) To reduce the output resistance of the amplifier.

(f) To reduce the effect of random changes of the parameters of the amplifier and supply voltage changes, and of any spurious defects.

A stage of this type is capable of fulfilling the highest fidelity requirements in a sound reproducing system. The output/input characteristic is of the type shown in Fig. 1 (b), and is virtually straight up to maximum output, when it curves sharply with the onset of grid current in the output stage. Non-linear distortion can be reduced to a degree represented by less than 0.1 per cent harmonic distortion, with no audible intermodulation. The frequency response of the whole amplifier from input to output transformer secondary can be made linear, and the power handling capacity constant over a range considerably wider than that required for sound reproduction.

The output resistance, upon which the loudspeaker usually depends for most of the damping required, can be reduced to a small fraction of the speech coil impedance. A ratio of load impedance/output resistance (sometimes known as "damping factor") of 20-30 is easily obtained.

"Kinkless" or "beam" output tetrodes used with negative feedback can, with care, be made to give a performance midway between that of triodes with and without feedback. The advantages to be gained from the use of tetrodes are increased power efficiency and lower drive voltage requirements.

The Williamson Amplifier

It must be emphasized that the characteristics of the stage are dependent solely upon the character and amount of the negative feedback used. The feedback must remain effective at all frequencies within the a.f. spectrum under all operating conditions, if the quality is not to degenerate to the level usually associated with tetrodes without feedback. Great care must be taken with the design and operation of the amplifier to achieve this, and troubles such as parasitic oscillation and instability are liable to be encountered.

When equipment has to be operated from low-voltage power supplies a tetrode stage with negative feedback is the only choice, but where power supplies are not restricted, triodes are preferable because of ease of operation and certainty of results.

It appears then that the design of an amplifier for sound reproduction to give the highest possible fidelity should centre round a push-pull triode output stage and should incorporate negative feedback.

The most suitable types of valve for this service are the PX25 and the KT66. Of these the KT66 is to be preferred since it is a more modern indirectly-heated type with a 6.3-volt heater, and will simplify the heater supply problem. Triode-connected it has characteristics almost identical with those of the PX25.

Using a supply voltage of some 440 volts a power output of 15 watts per pair may be expected.

The Output Transformer

The output transformer is probably the most critical component in a high-fidelity amplifier. An incorrectly designed component is capable of producing distortion which is often mistakenly attributed to the electronic part of the amplifier. Distortion producible directly or indirectly by the output transformer may be listed as follows:—

(a) Frequency distortion due to low winding inductance, high leakage reactance and resonance phenomena.

(b) Distortion due to the phase shift produced when negative feedback is applied across the transformer. This usually takes

the form of parasitic oscillation due to phase shift produced in the high frequency region by a high leakage reactance.

(c) Intermodulation and harmonic distortion in the output stage caused by overloading at low frequencies when the primary inductance is insufficient. This is primarily due to a reduction in the effective load impedance below the safe limit, resulting in a very reactive load at low frequencies. This may cause the valves to be driven beyond cut-off since the load ellipse will tend to become circular.

(d) Harmonic and intermodulation distortion produced by the non-linear relation between flux and magnetizing force in the core material. This distortion is always present but will be greatly aggravated if the flux density in the core exceeds the safe limit.

(e) Harmonic distortion introduced by excessive resistance in the primary winding.

The design of a practical transformer has to be a compromise between these conflicting requirements.

At a low frequency f_b , such that the reactance of the output transformer primary is equal to the resistance formed by the load resistance and valve a.c. resistances in parallel, the output voltage will be 3db below that at medium frequencies. At a frequency $3f_b$ the response will be well maintained, the transformer reactance producing only 20° phase angle. Similarly at the high frequency end of the spectrum the response will be 3db down at a frequency f_t such that the leakage reactance is equal to the sum of the load and valve a.c. resistances. Again at a frequency $f_t/3$ the

response will be well maintained.

If then the required frequency range in the amplifier is from 10–20,000 c/s, f_b may be taken as 3.3 c/s and f_t as 60 kc/s. A transformer which is only 3db down at frequencies as widely spaced as these would be difficult to design for some conditions of operation, and where this is so the upper limit may be reduced, as the energy content of sound at these frequencies is not usually high. The limiting factor will be the necessity of achieving stability when feedback is applied across the transformer, i.e., that the loop gain should be less than unity at frequencies where the phase shift reaches 180°.

To illustrate the procedure, consider the specification of an output transformer coupling two push-pull KT66 type valves to a 15-ohm loudspeaker load.

Primary load impedance = 10,000Ω

$$\text{Turns ratio} = \sqrt{\frac{10,000}{15}} = 25.8 : 1$$

$$\text{Effective a.c. resistance of valves} = 2500 \Omega$$

Low-frequency Response

Parallel load and valve resist-

$$\text{ance} = \frac{2500 \times 10,000}{12,500} = 2000 \Omega$$

$f_b = 3.3$ c/s ($\omega_b \approx 21$) response should be 3db down.

Primary incremental inductance

$$L = \frac{2000}{21} = 95 \text{ H.}$$

High-frequency Response

Sum of load and a.c. resistances

$$= 10,000 + 2500 \\ = 12500 \Omega$$

At $f_t = 60$ kc/s ($\omega_t = 376,000$), response should be 3db down.

$$\therefore \text{Leakage reactance} = \frac{12,500}{376} \\ = 33 \text{ mH.}$$

A 20-watt transformer having 10 primary and 8 secondary sections and using one of the better grades of core material can be made to comply with these requirements. Winding data will be given in an appendix (see page 11).

Some confusion may arise when specifying an output transformer as the apparent inductance of the windings will vary greatly with the method of measurement. The inductance of an iron-cored

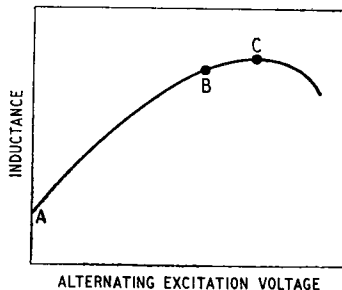

Fig. 2. Variation of iron-cored inductance with a.c. excitation.

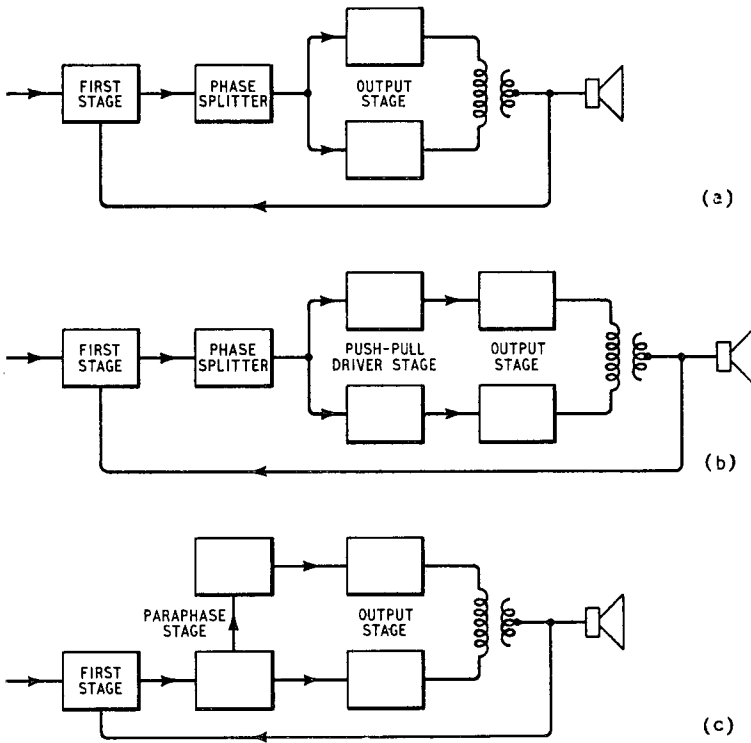

Fig. 3. Block diagrams of circuit arrangements discussed in the text.

component is a function of the excitation, the variation being of the form shown in Fig. 2. The exact shape of the curve is dependent on the magnetization characteristic for the core material.

The maximum inductance, corresponding to point C occurs when the core material is nearing saturation and is commonly 4-6 times the "low excitation" or "incremental" value at A, which corresponds to operation near the origin of the magnetization curve. In a correctly designed output transformer the primary inductance corresponding to the voltage swing at maximum output at 50 c/s will lie in the region of B in Fig. 2.

In specifying the component, the important value is the incremental inductance corresponding to point A, since this value determines the frequency response at low outputs.

Phase Shift

The reduction of phase shift in amplifiers which are to operate with negative feedback is of prime importance, as instability

will result, should a phase shift of 180° occur at a frequency where the vector gain of the amplifier and feedback network is greater than unity. The introduction of more than one transformer into the feedback path is likely to give rise to trouble from instability. As it is desirable to apply feedback over the output transformer the rest of the amplifier should be R-C coupled.

Alternative Circuits

Although the amplifier may contain push-pull stages it is desirable that the input and output should be "single ended" and have a common earth terminal. Three circuit arrangements suggest themselves.

The block diagram of Fig. 3 (a) shows the simplest circuit arrangement. The output valves are preceded by a phase splitter which is driven by the first stage. The feedback is taken from the output transformer secondary to the cathode of the first stage. This arrangement is advantageous in that the phase shift in the amplifier can easily be reduced

to a low value as it contains the minimum number of stages. The arrangement, however, has a number of disadvantages which render it unsuitable. The input voltage required by the phase splitter is rather more than can be obtained from the first stage for a reasonable distortion with the available h.t. voltage, and in addition the phase splitter is operating at an unduly high level. The gain of the circuit is low even if a pentode is used in the first stage, and where a low-impedance loudspeaker system is used, insufficient feedback voltage will be available.

The addition of a push-pull driver stage to the previous arrangement, as in Fig. 3 (b), provides a solution to most of the difficulties. Each stage then works well within its capabilities. The increased phase shift due to the extra stage has not been found unduly troublesome provided that suitable precautions are taken.

The functions of phase splitter and push-pull driver stage may be combined in a self-balancing "paraphase" circuit giving the arrangement of Fig. 3 (c). The grid of one drive valve is fed directly from the first stage, the other being fed from a resistance network between the anodes of the driver valves as shown in Fig. 4. This arrangement forms a good alternative to the preceding one where it is desirable to use the minimum number of valves.

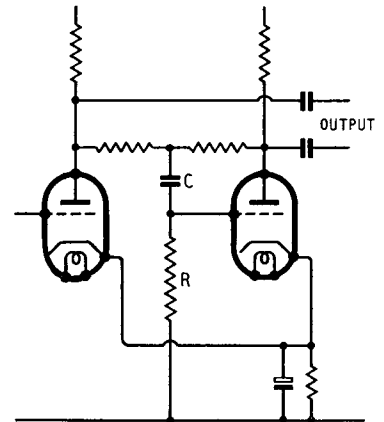

Fig. 4. "Paraphase" circuit combining the functions of phase splitter and push-pull driver stages.

Details of Chosen Circuit and Its Performance

THE considerations underlying the design of a high-quality amplifier were discussed in the first part of this article. A circuit of the complete amplifier is shown in Fig. 5. This follows the basic arrangement of Fig. 3(b). The design of the individual stages will not be treated in detail, but a review of the salient features may be of value. As a measure of standardization all valves except those of the output stage are type L63, triodes of about 8,000 ohms a.c. resistance.

Initial Stages.—In order to

keep the phase shift in the amplifier at low frequencies as small as possible the first stage has been directly coupled to the phase splitter, eliminating one R-C coupling. The first two stages are thus designed as a single entity. The phase-splitter section, which consists of a triode with equal loads in anode and cathode circuits, operates partly as a cathode follower, its grid being some 100 V positive with respect to chassis. The anode of the first triode is also arranged to be about 100 V positive and is coupled to the phase-

splitter grid. Due to the cathode-follower action of V_2 the operating conditions are not critical and no trouble is likely to be encountered from normal changes in valve parameters. The cathode bias resistor of V_1 , to which feedback is applied from the output transformer secondary, is kept as small as practicable to avoid gain reduction in the first stage, due to series feedback.

Driver Stage.—The output from the phase-splitter is taken to the push-pull driver stage. Provision is made for varying the load re-

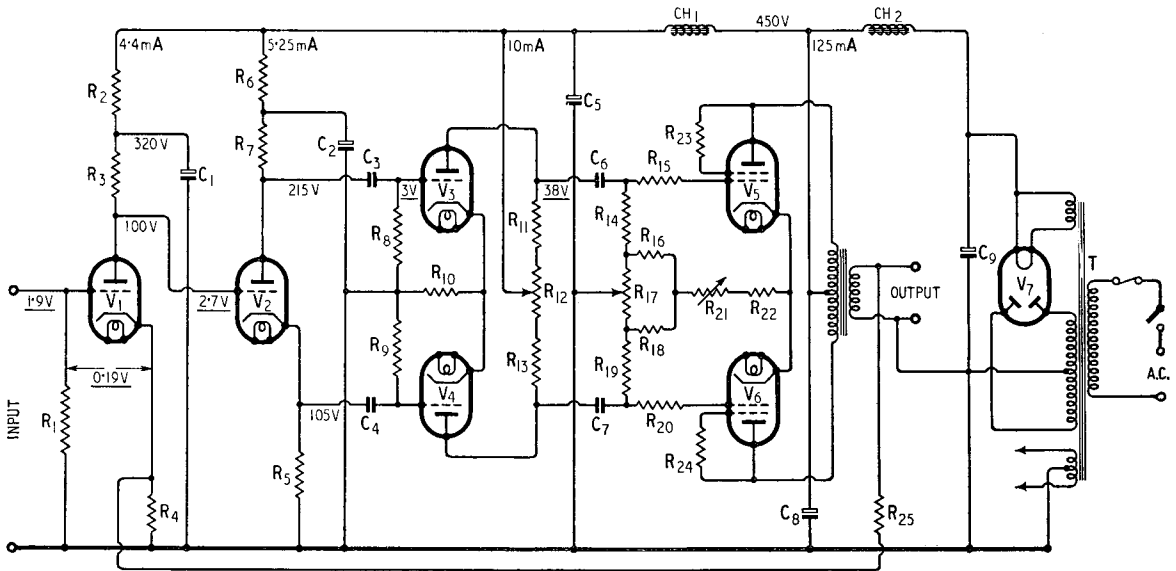

Fig. 5. Circuit diagram of complete amplifier. Voltages underlined are peak signal voltages at 15 watts output.

CIRCUIT VALUES

R_1	1 M Ω $\frac{1}{4}$ watt \pm 20 per cent	R_{15}, R_{20}	1,000 Ω $\frac{1}{4}$ watt \pm 20 per cent	C_8	8 μ F 550 V, wkg.
R_2	33,000 Ω 1 watt \pm 20 "	R_{16}, R_{18}	100 Ω 1 watt \pm 20 "	C_9	8 μ F 600 V, wkg.
R_3	47,000 Ω 1 watt \pm 20 "	R_{17}, R_{21}	100 Ω 2 watt wire-wound variable.	CH ₁	30 H at 20 mA (min.)
R_4	470 Ω $\frac{1}{4}$ watt \pm 10 "	R_{22}	150 Ω 3 watt \pm 20 "	CH ₂	10 H at 150 mA (min.)
R_5, R_6, R_7	22,000 Ω 1 watt \pm 10 "	R_{23}, R_{24}	100 Ω $\frac{1}{2}$ watt \pm 20 "	T	Power transformer.
R_8, R_9	0.47 M Ω $\frac{1}{4}$ watt \pm 20 "	R_{25}	$1,200 \sqrt{\text{speech coil impedance}}$ $\frac{1}{4}$ watt.		Secondary 425-0-425 V. 150 mA (min.) 5 V. 3A, 6.3 V. 4A, c.t.
R_{10}	390 Ω $\frac{1}{4}$ watt \pm 10 "	C_1, C_2, C_5	8 μ F 450 V, wkg.	V_1 to V_4	L63
R_{11}, R_{13}	39,000 Ω 2 watt \pm 10 "	C_3, C_4	0.05 μ F 350 V, wkg.	V_5, V_6	KT66.
R_{12}	25,000 Ω 1 watt wire-wound variable.	C_6, C_7	0.25 μ F 350 V, wkg.	V_7	U52
R_{14}, R_{19}	0.1 M Ω $\frac{1}{4}$ watt \pm 20 "				

The Williamson Amplifier

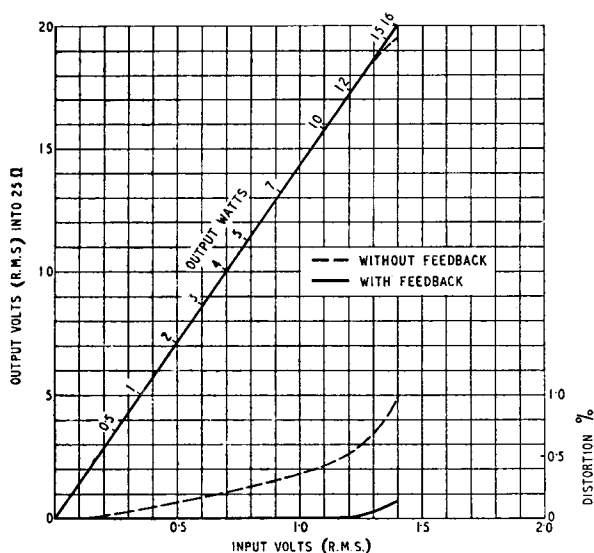
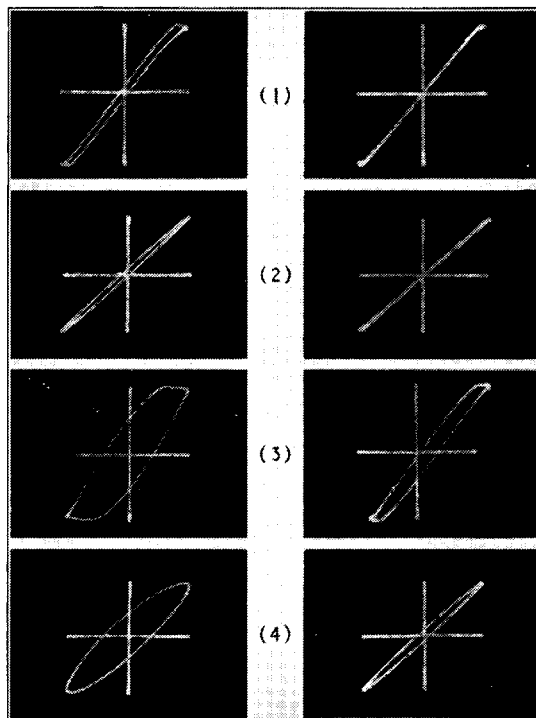

Fig. 6. Input-output characteristic and harmonic distortion curves, with and without feedback.

(Right)—

Oscillograms of input-output characteristic; left-hand column, without feedback; right-hand column, with feedback. (1) At 300 c/s with slight overload (2) At 300 c/s, output voltage 15% below maximum. (3) and (4) Conditions as in (1) and (2) respectively, but at 30 c/s.



sistors of this stage which, in conjunction with a common unby-passed cathode bias resistor, allows a considerable range of adjustment to be made in the drive voltages to the output valves to compensate for any inequality in gain.

Output Stage.—The balance of quiescent anode current in the output stage is a matter of some importance, as it affects the performance of the output transformer to a marked degree. In this amplifier, provision is made, by means of a network in the cathode circuits of the KT66 valves, for altering the grid bias of each valve, giving complete control of the static conditions of the stage. A feature of this arrangement is that the valves operate with a common unby-passed cathode bias resistor, which assists in preserving the balance of the stage under dynamic conditions.

Output Transformer.—The turns ratio of the output transformer will be determined by the impedance of the loudspeaker load. It is convenient to make each secondary section of such an

impedance that by series-parallel arrangement a number of suitable load impedances may be provided utilizing all the sections of the transformer. A suitable value of impedance is 1.7 ohms per section, giving alternatives of 1.7, 6.8, 15.3, 27 ohms, etc.

Winding data for a suitable transformer are given in the Appendix.

Negative Feedback Network.

The design of this amplifier is such that no difficulty should be experienced in the application of negative feedback up to a maximum of some 30 db. Provided that the threshold of instability is not reached, the benefits of negative feedback increase as the amount of feedback is increased, at the sole expense of loss of gain, but there will be little if any audible improvement to be gained with this amplifier by increasing the amount of feedback beyond 20 db.

The feedback network is a purely resistive potential divider, the bottom limb of which is the cathode bias resistor of the first stage.

With component values as

specified no trouble should be experienced from instability due to the effects of unintentional positive feedback. Should instability arise it will probably appear as oscillation at a supersonic frequency. This may be transient, occurring only at some part of the cycle when the amplifier is operated near maximum output. Its cause may be bad layout or an output transformer with a higher leakage reactance than specified, or it may be due to resonance in the output transformer.

A remedy, which should only be used as a temporary measure, is to reduce the high-frequency response of one of the amplifier stages, so reducing the loop gain at the frequency of oscillation to a value below unity. This may conveniently be done by connecting a small capacitor (say 200 pF) in series with a 5,000 Ω resistor from the anode of V_1 to chassis.

Performance

Linearity.—The linearity of the amplifier is well illustrated by the series of oscillograms. These show that, up to maximum output, the linearity is of a high order, and

The Williamson Amplifier

that the overload characteristic is of the desirable type shown in Fig. 1(b) in the previous issue. The improvement due to the application of negative feedback, especially at low frequencies, is clearly demonstrated by the oscillograms.

Equipment for measuring intermodulation products was not available, but measurement of the total harmonic distortion was made with an input frequency of 400 c/s. The result is shown in Fig. 6, from which it will be seen that the harmonic distortion at maximum rated output (15 watts) is less than 0.1 per cent. Intermodulation, with this degree of linearity, is not present to an audible degree.

Frequency Response.—The frequency response of the amplifier is greatly dependent upon the characteristics of the output transformer. In the amplifier tested, the output transformer had a resonance at about 60 kc/s which caused a sharp dip of 2.6 db around this frequency. The characteristic within the audible range from 10-20,000 c/s is linear within 0.2 db.

Phase Shift.—The excellence of the frequency response character-

istic indicates that little phase shift is present. Phase shift is only apparent at the extremes of the a.f. spectrum and never exceeds a few degrees.

Output Resistance.—The output resistance of the amplifier is 0.5 ohms measured at the 15-ohm output terminals.

Noise Level.—In the amplifier tested, the measured noise level was 85 db below maximum output. The noise in this amplifier was, however, almost entirely 50 c/s hum, caused by coupling between the mains and output transformers. By more careful arrangement of these components it appeared that the noise level could be reduced to better than 100 db below maximum output.

If desired, the power output of the amplifier may be increased beyond 15 watts by the use of several pairs of output valves in parallel push-pull. The output transformer, power supply and bias arrangements, and the feedback resistor R_{25} will require to be modified. Amplifiers of this design with power outputs up to 70 watts have been produced.

Listening tests carried out in conjunction with a wide-range loudspeaker system have fully

supported the measured performance. No distortion can be detected, even when the amplifier is reproducing organ music including pedal notes of the 20 c/s order, which reach the threshold of maximum output. Transients are reproduced with extreme fidelity; tests using a direct microphone circuit with noises such as jingling keys reveal extraordinary realism.

The amplifier can be described as virtually perfect for sound-reproducing channels of the highest fidelity. It provides an ideal amplifier for sound-recording purposes, where "distortionless" amplification and low noise level are of prime importance.

APPENDIX.

Output Transformer.

Specification.

Primary load impedance	= 10,000 ohms c.t.
Secondary load impedance	= 1.7 ohms per section.
Turns ratio	= 76 : 1.
Primary inductance	= 100 H (min.)
Leakage inductance	= 30 mH (max.)

Winding Data.

Core: $1\frac{1}{4}$ in stack of Pattern No. 28A "Super Silcor" laminations (Magnetic and Electrical Alloys, Burbank, Hamilton, Lanarks).

The winding consists of two identical interleaved coils, each $1\frac{1}{4}$ in wide, wound on $1\frac{1}{4}$ in \times $1\frac{1}{4}$ in paxolin formers. On each former is wound: 5 primary sections each consisting of 5 layers (88 turns per layer) of 30 s.w.g. enamelled copper wire interleaved with 2 mil. paper, alternating with 4 secondary sections, each consisting of 2 layers (29 turns per layer) of 19 s.w.g. enam. copper wire, interleaved with 2 mil. paper.

Each section is insulated from its neighbours by 3 layers of 5 mil. Empire tape. All connections are brought out on one side of the winding, but the primary sections may be connected in series when winding, only two primary connections per coil being brought out.*

Measured Performance.

Primary inductance	= 100 H.
(measured at 50 c/s with 5V r.m.s. on primary, equivalent to 2.5 mW)	
Leakage inductance	= 22 mH.
(measured at 1,000 c/s)	
Primary resistance	= 250 ohms.

* Secondary connections for different ratios are given in the Table on p.17.

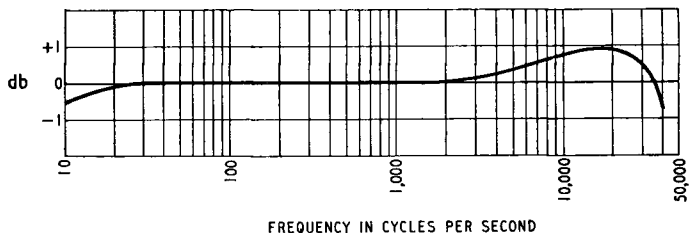
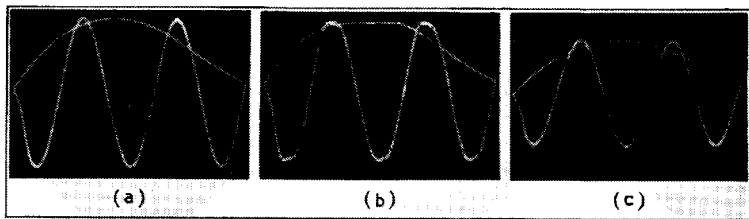

Fig. 7. Frequency response (without feedback) of 20 watt output transformer described in appendix. Generator resistance 2,500 Ω load resistance 1.7 Ω . Measured with 5V r.m.s. on primary. At higher excitations the bass response improves progressively up to saturation.



(a) Input waveform, 300 c/s. (b) Output waveform with feedback and slight overload. (c) Output waveform with feedback but output voltage 15% below maximum.

The New Version

Design Data: Modifications: Further Notes

SINCE the publication in the April and May, 1947, issues of *Wireless World* of an amplifier design suitable for high-quality reproduction of sound, correspondence has revealed that a more complete explanation of some of the features of the design, with the addition of some information about construction, would be of interest. The correspondence also shows that considerable demand exists for a pre-amplifier unit to enable the amplifier to be used in conjunction with gramophone pickups and microphones of low output. In the present article it is proposed to deal with the

amplifier, and in subsequent articles to present the design of auxiliary equipment to form a domestic sound-reproducing installation.

Circuit Diagram. The list of component values are printed again. These differ in minor detail from the originals. In the circuit previously printed a potentiometer, R_{12} , was provided in the penultimate stage to enable the signal to be balanced. Due to the use of common unbypassed cathode resistors for the push-pull stages, the amplifier is largely self-balancing to signal, and it is permissible to dispense with this

adjustment. Accordingly, revised values and tolerances are shown for resistors R_5 , R_7 , R_{11} and R_{13} .

A transitional phase-shift network consisting of R_{26} and C_{10} , which was previously recommended as a temporary measure, has been added as a permanent feature to increase the margin of stability at high frequencies. This will be discussed later when the stability of the amplifier is considered.

Finally, an indirectly-heated rectifier has been substituted as this prevents a damaging voltage surge when the amplifier is switched on. No suitable type was

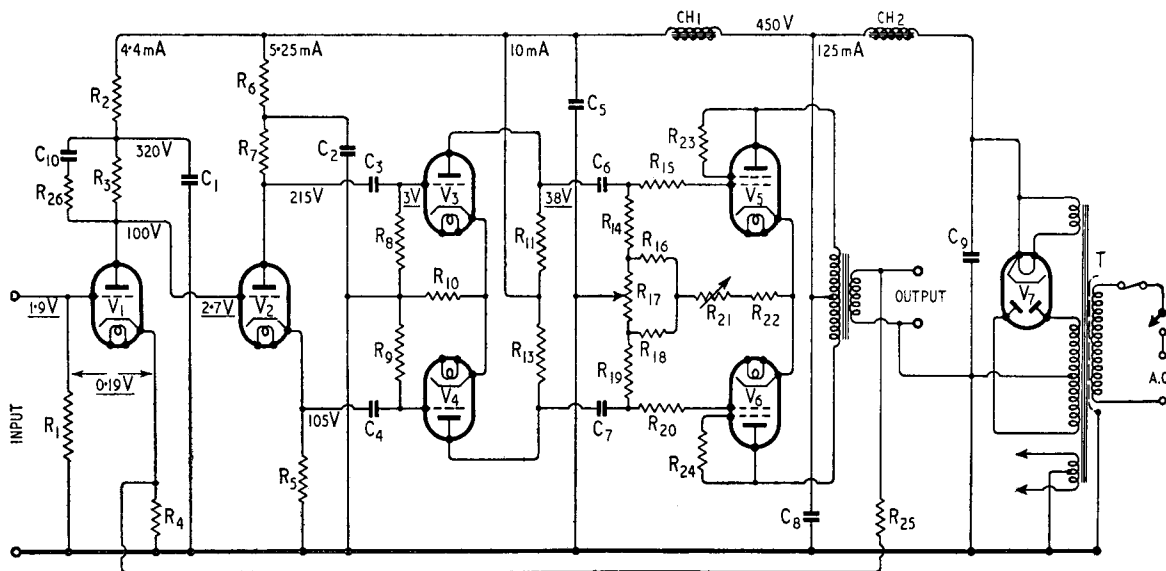

Fig. 1. Circuit diagram of complete amplifier. Voltages underlined are peak signal voltages at 15 watts output.

R_1	1M Ω	$\frac{1}{2}$ watt \pm 20%
R_2	33,000 Ω	1 watt \pm 20%
R_3	47,000 Ω	1 watt \pm 20%
R_4	470 Ω	$\frac{1}{2}$ watt \pm 10%
R_5, R_7	22,000 Ω	1 watt \pm 5% (or matched)
R_6	22,000 Ω	1 watt \pm 20%
R_8, R_9	0.47M Ω	$\frac{1}{2}$ watt \pm 20%
R_{10}	390 Ω	$\frac{1}{2}$ watt \pm 10%
R_{11}, R_{18}	47,000 Ω	2 watt \pm 5% (or matched)

R_{14}, R_{19}	0.1M Ω	$\frac{1}{2}$ watt \pm 10%
R_{15}, R_{20}	1,000 Ω	$\frac{1}{2}$ watt \pm 20%
R_{16}, R_{18}	100 Ω	1 watt \pm 20%
R_{17}, R_{21}	100 Ω	2 watt wirewound
R_{22}	150 Ω	3 watt \pm 20%
R_{23}, R_{24}	100 Ω	$\frac{1}{2}$ watt \pm 20%
R_{25}	1,200	$\sqrt{\text{speech coil impedance}}$ $\frac{1}{2}$ watt (see table)
R_{26}	4,700 Ω	$\frac{1}{2}$ watt \pm 20%
C_1, C_2, C_5, C_8	8 μ F	500V wkg.
C_3, C_4	0.05 μ F	350V wkg.

C_6, C_7	0.25 μ F	350V wkg.
C_9	8 μ F	600V wkg.
C_{10}	200pF	350V wkg.
CH ₁	30H	at 20mA
CH ₂	10H	at 150mA
T	Power transformer	
Secondary	425-0-425V 150 mA, 5V, 3A, 6.3V 4A, centre-tapped	
V_1, V_2	2 \times L63 or 6J5, 6SN7 or B65	
V_3, V_4	do. do.	
V_5, V_6	KT66	V_7 Cossor 53KU, 5V4

The Williamson Amplifier

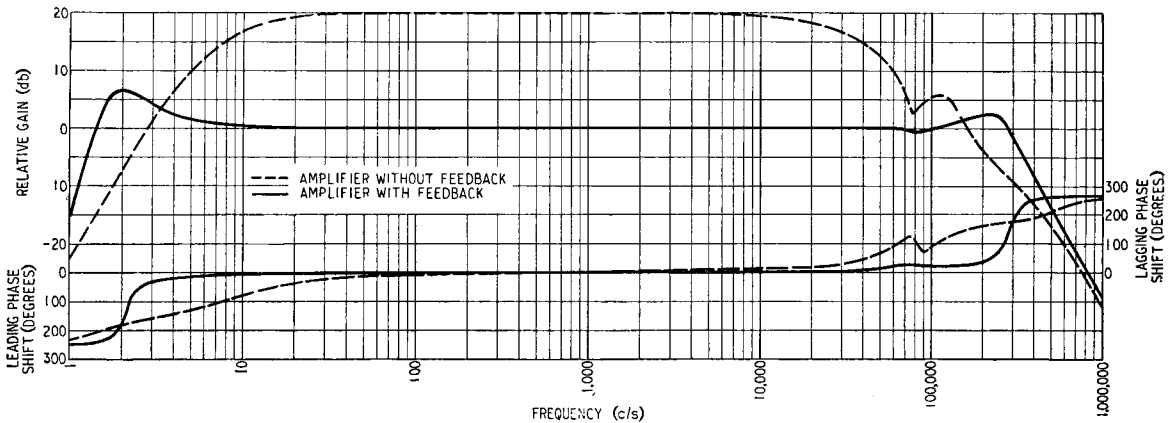

Fig. 2. Loop gain and phase-shift characteristics of the amplifier.

available when the circuit was originally published. A list of alternative valve types is also shown.

Amplitude and Phase/frequency Response. A curve showing the transmission and loop gain of the amplifier at frequencies between 1 c/s and 1 Mc/s is shown in Fig. 2. Although only the section between 10 c/s and 20,000 c/s is useful for sound reproduction, the curves outside this range are included as they may be of interest to those who may wish to use the amplifier for other purposes. They may also serve to emphasize that, in a feedback amplifier, the response must be carefully controlled at frequencies very remote from the useful range if stability is to be achieved.

General Constructional Data. The layout of the amplifier is not critical, provided that a few simple precautions are observed. Many different arrangements have been used satisfactorily to suit differing circumstances. An excellent plan is to construct the power supply and the amplifier on separate chassis, as this gives greater flexibility in accommodating the equipment in a cabinet.

The following precautions should be observed:—

1. The output transformer core should be positioned at right angles to the cores of the mains transformer and the main smoothing choke.

2. The output transformer and loudspeaker leads should be kept at a reasonable distance from the input leads, which should be screened. As the response curve

Fig. 3. Suggested layout of principal components of combined amplifier and power pack.

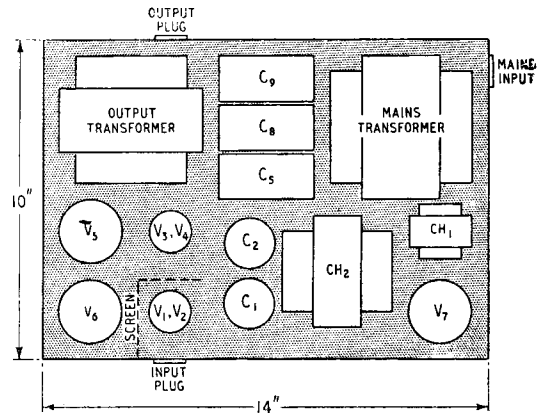

shows, the amplifier has considerable gain at low radio frequencies, and care is necessary to avoid oscillation.

3. Signal wires, especially grid leads, should be kept as short as possible, and the stopper resistors associated with the output stage must be mounted on the valve-holder tags, and not on group panels.

4. A bus-bar earth return formed by a piece of 12 or 14 s.w.g. tinned copper wire, connected to the chassis at the input end, is greatly to be preferred to the use of the chassis as an earth return.

5. Electrolytic and paper capacitors should be kept away from sources of heat, such as the output and rectifier valves.

Figs. 3 and 4 show the positions of the major components in two alternative layouts which have been used successfully.

Initial Adjustments. Before

the amplifier is put into service there are a few adjustments which require to be made. These concern the balancing of the standing currents in the output stage, and (*with the original circuit*) balancing of the signal currents in the push-pull stages.

Accurate balance of the standing currents in the output stage is essential, as the low-frequency characteristics of the output transformer deteriorate rapidly with d.c. magnetization. The procedure to be adopted for static and signal balancing is as follows:—

Static Balancing.

- (a) Connect a suitable milliammeter in the lead to the centre tap of the output transformer primary.

- (b) Set the total current to 125 mA by means of R_{21} .

- (c) Connect a moving-coil voltmeter (0-10 V approx.) across the whole of the output

The Williamson Amplifier

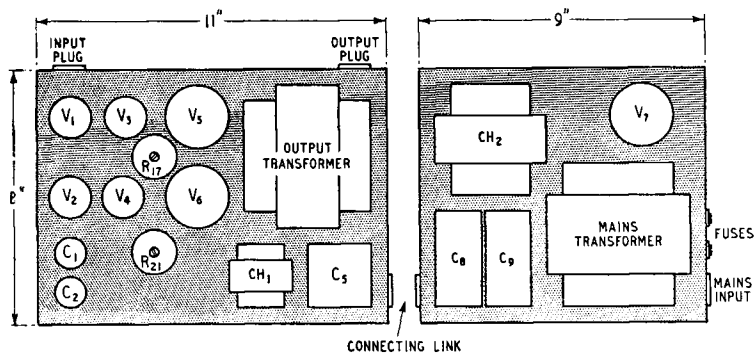

Fig. 4. Layout when using separate power pack.

transformer primary and adjust R_{17} until the reading is zero, indicating balance. Random fluctuations of this instrument may be noticed. These are due to mains and valve fluctuations and should be disregarded.

Signal Balancing.

(a) Connect the low-impedance winding of a small output transformer in the lead to the centre tap of the output transformer. Connect a detector (headphones or a cathode-ray oscillograph if available) to the other winding, earthing one side for safety.

(b) Connect a resistive load in place of the loudspeaker.

(c) Apply a signal at a frequency of about 400 c/s to the amplifier input to give an output voltage about half maximum.

(d) Adjust R_{12} for minimum output in the detector.

The Output Transformer. As stated previously, the output transformer is the most critical component in the amplifier and satisfactory performance will not be obtained with a component differing substantially from the specification. The effect of decreasing the primary inductance will be to produce instability at low frequencies, which can be cured only by altering the time constants of the other coupling circuits, or by decreasing the amount of feedback. At high frequencies the situation is more complex, as there are more variables. The leakage inductance, the self-capacitance of the windings, the capacitance between windings and the distribution of these parameters determine the

transmission of the component at high frequencies, and great variations are possible.

In the output transformer specified, the only parameter which is likely to vary appreciably is the inductance of the primary at low signal levels, due to the use of core material with a low initial permeability, or to careless assembly of the core. The high-frequency characteristics are not dependent on the core material to a substantial degree. They are dependent only on the geometry of construction, and to some extent upon the dielectric properties of the insulants used, and are therefore reproducible with a high degree of accuracy.

Comments are frequently expressed about the size of the output transformer. It is true that it is considerably larger than the transformers which are usually fitted to 15-watt amplifiers. The fact that the peak flux density of 7,250 gauss for maximum output at 20 c/s lies on the upper safe limit for low distortion is sufficient comment on current practice.

Some confusion arose regarding the method of connection of the transformer secondary windings to match loads of various impedances, whilst utilizing all the secondary sections. The correct primary load impedance is $10,000\Omega$ and as the turns ratio in the original design is 76:1 the impedance of each secondary section is $10,000\Omega/76^2$ or 1.7Ω . When secondary sections are connected in parallel, the turns ratio, and hence the impedance ratio, remains unchanged. If now two secondary sections, or sets of paralleled sections, are connected in series the turns ratio is halved,

and the secondary impedance, being proportional to the square of the turns ratio, becomes $1.7 \times 2^2 = 6.8\Omega$. Similarly if three sections are connected in series the impedance becomes $1.7 \times 3^2 = 15.3\Omega$. Thus the available secondary impedances, keeping a $10,000\Omega$ primary load impedance, are 1.7, 6.8, 15.3, 27, 42.5, 61, 83 and 109Ω . The connections to obtain these values are shown in the table.

Should it be necessary, in an emergency, to match loads of other impedances to the amplifier, it is permissible to reduce the primary load impedance to $6,000\Omega$ giving another series of secondary impedances, namely 1, 4, 9, 16, 25, 36, 49 and 64Ω . Under these conditions the power output will be increased slightly and the distortion will be doubled. The value of the feedback resistor R_{25} must remain unaltered, as the turns ratio is unchanged. The values of R_{25} are given in the table.

Winding data for an output transformer to match loads in the region of 3.5Ω are given in the Appendix and the connections and other data are included in the lower section of the table.

The two outer layers of the output transformer primary should normally be connected together to form the centre tap, the inner sections of the winding being taken to the valve anodes. This gives the minimum external electric field.

Stability with Negative Feedback.—Much has been written about the stability of amplifiers under conditions of negative feedback, and the criteria for stability are now widely appreciated. The article by "Cathode Ray" in the May, 1949, issue, states the matter simply and with characteristic clarity.

Continuous oscillation will occur in a feedback amplifier if the loop gain—that is the transmission of the amplifier and the feedback network—is greater than unity at any point where the phase shift of the amplifier has reached 180° . It is also possible for an amplifier to be unstable in the absence of continuous oscillation if these conditions should occur in a transient manner at a critical signal level. This latter condition is particularly likely to occur in badly de-

The Williamson Amplifier

signed amplifiers with iron-cored components, where the inductance and, therefore, the time constant controlling the phase and amplitude characteristics of one or more stages may increase by as much as a factor of five between zero and maximum signal levels. If this variable time constant is shorter than those of the fixed coupling circuits, an increase in its value due to a high signal level may be sufficient to render the system unstable. In order to avoid this condition the fixed time constants must be made much longer than that of the variable stage. This condition would lead to undesirably large interstage couplings if good low-frequency response were required. Alternatively, the variable time constant must be chosen in relation to the fixed time constants, such that its minimum value is sufficiently longer than the fixed values to produce stability. An increase in its value then serves only to increase the stability margin. This method is used in the amplifier under discussion.

To ensure a wide margin of stability, whilst at the same time preserving the high loop gain necessary to reduce the effect of

transformer distortion at frequencies of the order of 10-20 c/s, would require a transformer with a very large initial primary inductance. This would necessarily be expensive, and a compromise must be drawn between the three factors. Because of this, the margin of stability must be kept to the lowest practicable value.

When the amplifier is reproduced, the "spread" in tolerance of components will normally be such that changes in characteristics due to departure from the nominal value of one component will be balanced by opposite changes produced by departure in another component, and the amplifier as a whole is likely to have characteristics close to the average. Individual amplifiers may, however, have characteristics which differ substantially from the average, due to an upward or downward trend in the changes produced by component deviations. If the trend is in a direction such that the loop gain is reduced, no instability will result, the only effect being a slight degrading of the performance. If, on the other hand, the loop gain is increased by an amount greater than the







margin of stability, oscillation will occur. It should be emphasized that this will happen only very rarely, and when it does the remedy is obviously to reduce the loop gain to its correct value.

To assist the unfortunate few who experience instability, the following procedure is recommended. If oscillation should occur at a low frequency (about 2 c/s) the first step should be to disconnect the feedback resistor R_{25} . If the oscillation continues the decoupling circuits should be checked and any faulty components replaced. The amplifier should also be examined to ensure that it is operating correctly balanced in push-pull, and not in an unbalanced manner due to the failure of some component.

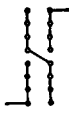
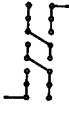
Primary Inductance

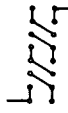
Assuming that the amplifier is, or has been rendered, stable with the feedback disconnected, the next step should be to check the phase and amplitude characteristics at low frequencies. It is not practicable to make direct measurements of these characteristics without very special equipment, as inspection of Fig. 2 will show that the interesting region lies

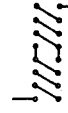
OUTPUT TRANSFORMERS. TABLE OF CONNECTIONS.

		1	2	3	4	5	6	7	8
No. of secondary groups of sections in series									
Connections									
Original Output Transformer 10,000/1.7Ω	Correct secondary impedance (ohms)	1.7	6.8	15.3	27	42.5	61	83	109
	Minimum secondary impedance permissible (ohms)	1	4	9	16	25	36	49	64
	Feedback resistor R_{25} (ohms)	1,500	3,300	4,700	6,800	8,200	10,000	11,000	12,000
	Turns ratio	76	38	25.4	19	15.2	12.6	10.8	9.5
Alternative Output Transformer (See Appendix) 10,000/3.6Ω	Correct secondary impedance (ohms)	3.6	14.4	32.5	57.5	90	130	176	230
	Feedback resistor R_{25} (ohms)	2,200	4,700	6,800	9,000	11,500	13,500	16,000	18,000
	Turns ratio	52.5	26.25	17.5	13	10.5	8.75	7.5	6.5

The Williamson Amplifier

below 10 c/s. It is therefore necessary to arrive at the desired result by indirect means, namely by measurement of the component parameters which determine the characteristics. The parameter which is most likely to show a large deviation from specification is the initial primary inductance of the output transformer, since the quality of the core material is not easy to control accurately, and careless assembly of the core may cause considerable variations in its permeability.

The initial primary inductance should be checked by connecting the primary winding across the 5-V, 50-c/s rectifier heater winding of the mains transformer and measuring the current in it. The secondary windings should be on open circuit. The current, which can just be read on the 10 mA a.c. range of a Model 7 Avometer, should be 150 μ A or lower. The component should be rejected if the current exceeds 200 μ A.

If the output transformer is satisfactory the values of the other components should be checked, particular attention being paid to the coupling components. Should the time constants of the couplings, that is their RC product, be higher than the nominal values by more than 20 per cent, the resistors should be adjusted to give the correct value.

The trouble will probably have revealed itself by this time, but, if upon reconnecting R_{25} the oscillation is still present, it is very likely to be due to the use of valves with mutual conductances higher than average, and it is legitimate to increase the value of R_{25} to reduce the loop gain. If instruments are available, the loop gain may be measured by disconnecting R_{25} from the cathode of V_1 and reconnecting it via a $470 \Omega \pm 10$ per cent resistor to chassis. The voltage gain, measured from the input grid to the junction of R_{25} and the 470Ω resistor, should be 10 at frequencies between 30 c/s and 10 kc/s. Care must be taken not to overload the amplifier when this measurement is being made.

The adjustment of the loop gain to its correct value at medium frequencies should render the amplifier stable at high frequencies. It is unlikely that the phase characteristic at high fre-

quencies of individual amplifiers will deviate appreciably from normal unless the layout is very poor or the transformer is not to specification.

Capacitive Loads

The amplifier is absolutely stable at high frequencies with a resistive or inductive load, but it is possible for oscillation to occur when the load impedance is capacitive at very high frequencies, for example, when a long cable is used to connect the amplifier and loudspeaker. To avoid this possibility, and to give an increased margin of stability, a transitional phase-shift network consisting of R_{26} and C_{10} in conjunction with the output resistance of V_1 , has been included in the circuit. This has the effect of reducing the loop gain at frequencies from 20 kc/s upwards without affecting the phase shift in the critical region.

The use of a phase advance network consisting of a capacitor shunting R_{25} has been advocated as a means of stabilizing this amplifier. The effect of such a network is to increase the loop gain at high frequencies, at the same time reducing the amount of phase lag. It is sometimes possible by this means to steer the phase curve away from the 180° point as the loop gain is passing through unity, thus increasing the margin of stability.

The connection of a capacitor across R_{25} , however, will not stabilize this amplifier if it has been constructed to specification, although it may produce improvement if oscillation is due to some large departure from specification, such as the use of an output transformer with completely different high-frequency characteristics. The writer has no information about this.

The use of separate RC bias impedances for the output valves has also been suggested. This procedure is not endorsed by the writer, as there are numerous disadvantages in its use and no redeeming features whatsoever. If the time constant of the bias network is made sufficiently long to ensure that the low-frequency performance of the amplifier is unimpaired, the phase shift of the bias network will have its maximum at or near the lower critical frequency and may provoke

oscillation. If, on the other hand, it is made sufficiently short to avoid this, the ability of the amplifier to handle low frequencies will be impaired. The use of separate bias impedances destroys the self-balancing properties of the amplifier, and if two dissimilar valves are used in the output stage "motor boating" is likely, due to the presence of signal in the h.t. line. The performance of the output transformer may be seriously affected by the out-of-balance current caused by valves whose anode currents lie within the manufacturer's tolerance limits. Finally, there can be little justification of this modification on economic grounds, as the costs are roughly similar. Indeed, if the question of replacement due to failure is considered, the common bias arrangement shows a definite saving.

It is to be hoped that these remarks on stability will not have the effect of frightening those who already possess amplifiers of this type or are contemplating acquiring them. Their purpose is to help the occasional "outer limit" case where instability is experienced, but if they serve to impress upon the reader that negative feedback amplifiers are designed as an integral unit, and that any modifications, however insignificant they may appear, may seriously affect the performance or stability, a useful purpose will have been accomplished. Such modifications should be attempted only by those who are confident that they know what they are doing, and who have access to measuring equipment to verify results.

APPENDIX

Output Transformer with 3.6-ohm Secondaries

Winding Data

Core: $1\frac{1}{2}$ in. stack of 28A Super Silcor laminations. (Magnetic and Electrical Alloys, Burnbank, Hamilton, Lanarks.). The winding consists of two identical interleaved coils each $1\frac{1}{2}$ in. wide on paxolin formers $1\frac{1}{4}$ in. \times $1\frac{1}{2}$ in. inside dimensions. On each former is wound 5 primary sections, each consisting of 440 turns (5 layers, 88 turns per layer) of 30 s.w.g. enamelled copper wire interleaved with 2 mil. paper, alternating with 4 secondary sections, each con-

The Williamson Amplifier

sisting of 84 turns (2 layers, 42 turns per layer) of 22 s.w.g. enamelled copper wire interleaved with 2 mil. paper. Each section is insulated from its

neighbours by 3 layers of 5 mil. Empire tape. All connections are brought out on one side of the winding, but the primary sections may be connected in series when winding,

two primary connections only per bobbin being brought out. Windings to be assembled on core with the bobbin reversed, and with insulating cheeks and centre spacer.

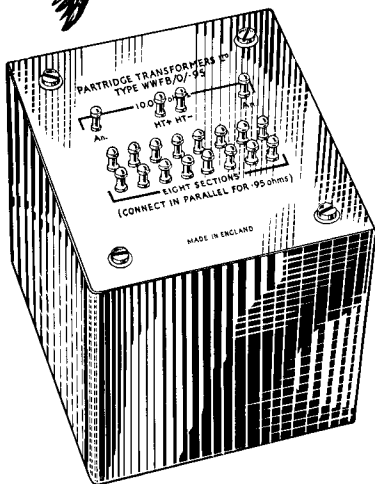

Why the **WILLIAMSON** **AMPLIFIER** should employ **PARTRIDGE** Transformers

THE widest possible audio range—the lowest possible distortion and an output of 20 watts . . . these critical demands of the designer of this now famous Amplifier implied the finest that technical skill and craftsmanship could provide for every component. Little wonder that from the inception of the Williamson Amplifier in 1947 Partridge have specialised in the transformers and chokes. The all important output transformer was the special care of Partridge and this “Williamson specification” component is now available for a varied range of impedance. (A model is also available for American 807 tubes, see the modified circuit in “Audio Engineering,” November 1949.) All secondary windings are brought out as eight separate sections of equal impedance. Stock types comprise 0.95 ohm, 1.7 ohm, 3.6 ohm and 7.5 ohm sections; this latter giving a 500 ohm secondary for American requirements. *The Partridge “Williamson” Output Transformer is acknowledged the most efficient of its type.*

Available

UNPOTTED (Style VDN/436B)

or

POTTED (Style VDN/436B)

Technical data sheets with fullest details (complete with alternative mountings) are available on request. Also available, complete catalogue of the Partridge range including the mains components for this and other amplifiers.

★ **IMMEDIATE DELIVERY** can be made, and these components are ready for shipment to all parts of the world.

PARTRIDGE
TRANSFORMERS LTD

ROEBUCK ROAD : KINGSTON BY-PASS : TOLWORTH : SURREY : Elmbridge 6737/8

Design of Tone Controls and Auxiliary Gramophone Circuits

MOST power amplifiers intended for sound reproduction are designed to have a uniform response to frequencies within the audible range, and it is the aim of designers of pickups, microphones and loudspeakers to give similar characteristics to their products. This represents an attempt to fulfil one of the conditions for the creation of a perfect replica of the original sound and provides a common basis for the design of individual units, which, when connected together, will provide a complete channel with a uniform gain/frequency characteristic.

Considerations of an engineering nature sometimes make it desirable, and even essential, to depart from this ideal of a uniform response in certain sections of equipment, and quite frequently the use of inferior equipment or long and unsuitable transmission lines leads to an undesirable departure from uniformity. In cases like this, other "equalizer" units have to be inserted in the channel to provide characteristics which are the inverse of those of the offending section, so remedying the defect.

When listening conditions depart from the ideal—and this, unfortunately, happens frequently since most rooms are unsuitable auditoria for the reproduction of orchestral music at realistic intensities—it is sometimes beneficial to modify the frequency response characteristic of the equipment in an attempt to compensate for the more obvious defects in the room acoustics. The word "attempt" is used advisedly, since only very complex equalization could ever hope to provide accurate compensation for room acoustics. This question of the frequency compensation which is desirable when conditions depart from the ideal is a very thorny and subjective one. It provokes much heated, dogmatic, and usually very unscientific discussion, and is beyond the scope of

the present article. It must suffice to say that the matter is one in which the individual must exercise his own judgment and act accordingly.

In order that he may have scope to do this, a pre-amplifier designed to be used in conjunction with gramophone recordings and radio transmissions should therefore be capable of providing variable compensation for such defects as are likely to occur in the

source, and are capable of being ameliorated. In addition, fixed compensation must be provided for deviations from a uniform response which are deliberately introduced in gramophone records.

The degree of complication which is worthwhile in such a unit must be considered. In theory, it is possible to compensate precisely for deficiencies in the amplitude/frequency and phase/frequency response charac-

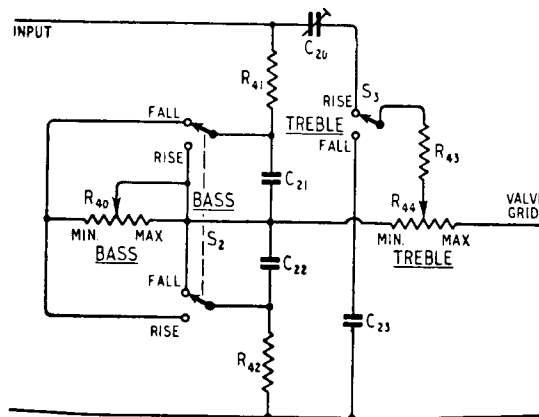

Fig. 5. Basic frequency compensation circuit. Typical values (for use after an EF37, triode-connected) are: R₄₀, 250kΩ, log; R₄₁, 100kΩ; R₄₂, 6.8kΩ; R₄₃, 10kΩ; R₄₄, 100kΩ linear. C₂₀, 150pF max.; C₂₁, 0.01μF, C₂₂ 0.05μF; C₂₃, 1000pF.

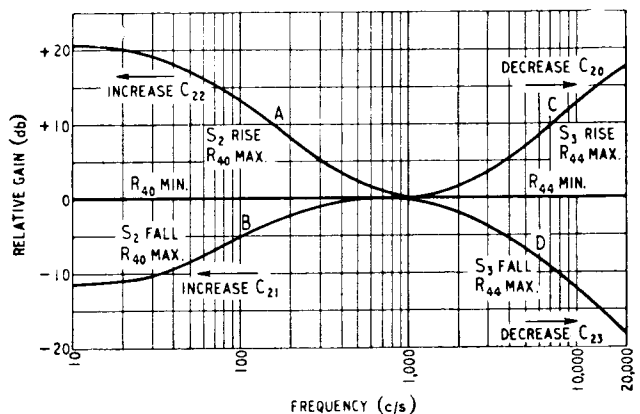

Fig. 6. Response curves of circuit of Fig. 5.

The Williamson Amplifier

teristics, but the equipment to do this is complicated and expensive. When a considerable portion of the channel is outside the control of the listener, as is the case when reproducing records or broadcast transmissions, he has no means, apart from the sensitivity and training of his ears, of determining the defects which have occurred in that portion. Since it is impossible to determine the nature and amount of phase distortion by listening to a transmission, and since it is not usual for much attention to be paid to this form of distortion at the recording or transmitting end, there would seem to be little justification for the inclusion of phase correcting networks in domestic equipment. In the case of a sound reproducing system which is completely under the control of the user, particularly if stereophonic, phase distortion should not be allowed to occur if the finest possible quality is to be obtained. This is especially true at low frequencies, where considerable time delays are involved. Low phase distortion is best achieved by designing a system with a bandwidth considerably greater than the audible range, but where this is not possible compensation may be provided.

Consideration of the causes of frequency distortion leads to the conclusion that it is normal for the levels at the ends of the spectrum to be accentuated or attenuated progressively with respect to the level at middle frequencies and a form of compensation to correct this fulfils most requirements. It is not possible to lay down hard and fast rules about the amount of compensation necessary, but rates of attenuation or accentuation greater than 6 db/octave are not usually required.

As it is often desirable to change the amount of compensation during a programme without calling attention to the fact, methods which give continuous control over the response are to be preferred to switched systems, unless the latter are graded in very fine steps.

The use of inductors to provide gain/frequency compensation is to be deprecated as, apart from possible troubles due to resonance effects and non-linearity, they are very liable to pick up hum from

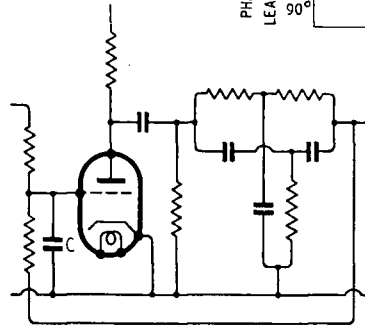

Fig. 7. Basic filter circuit.

stray alternating magnetic fields, especially if they are air-cored. Metal- or dust-cored toroids are less troublesome in this respect, but are expensive and not readily obtainable.

Frequency Compensation.—Fig. 5 shows a simple compensation circuit which will accomplish bass and treble accentuation and attenuation without the use of inductors. The controls consist of two potentiometers, each associated with a changeover switch. Consider the low frequency controls R_{10} and S_2 . When R_{10} is fully anticlockwise (minimum resistance) the response to frequencies below 1,000 c/s is uniform. If the switch S_2 is set to "rise," as R_{10} is rotated clockwise, the amplitude/frequency characteristic will rise at low frequencies to the maximum shown at A in Fig. 6. If S_2 is set to "fall" and R_{10} rotated clockwise from the minimum position, progressive low-frequency attenuation will be introduced, up to the maximum shown at B. In a similar manner, by the use of R_{11} and S_3 the high-frequency response is continuously variable from a level response to the extremes shown at C and D with the values given. The curves may be shifted bodily along the horizontal axis by modifying the capacitance values as shown by the arrows in Fig. 6.

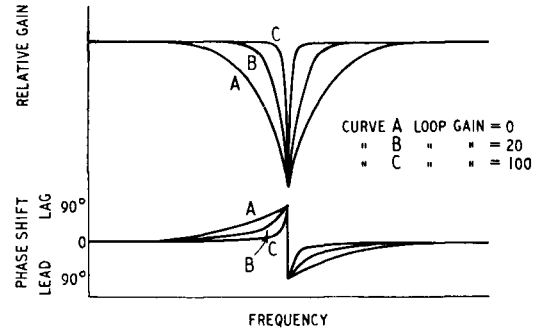

Fig. 8. Characteristics of circuit of Fig. 7.

The attenuation introduced by the network when controls are at the level position is 24 db, and the network must, of course, be introduced into the system at a signal level such that the valve feeding is not overloaded.

Low-Pass Filter.—The majority of medium-wave broadcast transmissions, when reproduced with wide-range equipment, exhibit a most objectionable form of non-linear distortion. This takes the form of a rattle or buzz often accompanying transient sounds such as pianoforte music. This type of distortion is commonly caused by minor discontinuities in the transfer characteristic and is frequently associated with Class "B" amplifiers.

Recording and processing defects, record wear and imperfect tracing by the pickup produce a similar type of distortion from gramophone records.

The most offensive frequency components of the rattle or buzz are generally present at the extreme upper end of the audible spectrum, and spread downwards as the severity of the effect increases. Fortunately, the concentration of this type of distortion into the extreme upper end of the spectrum makes it possible to effect considerable improvement by removing or reducing the energy in the signal at these frequencies. A low-pass filter with a cut-off frequency variable between the limits of 5 and 13 kc/s and a fairly high rate of attenuation above the cut-off frequency is a great asset in securing the best possible aural result from indifferent transmissions or recordings.

Although it is practicable to provide a filter with a continu-

The Williamson Amplifier

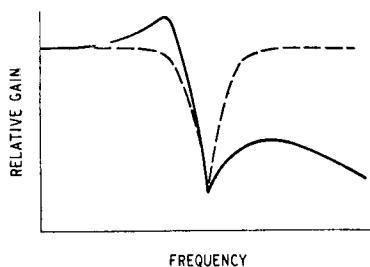

Fig. 9. Modification of basic filter characteristic produced by additional phase shift.

ously variable cut-off frequency, the expense and complication are not normally justified and a switched selection of frequencies is satisfactory. To attain the high attenuation rates necessary to secure satisfactory results a normal resonant-section type of filter could be used, but this carries with it the disadvantages associated with the use of inductors.

An alternative type of filter using only resistive and capacitive elements based on the parallel-T network¹ is capable of giving very satisfactory results. Briefly, the principle of this filter is as follows. In Fig. 7 is shown an amplifier feeding a parallel-T null network, the output from the network being fed back to the input of the amplifier. Such a system has amplitude and phase characteristics of the general shape shown in Fig. 8. By altering the loop gain of the amplifier, it is possible to produce a resonance characteristic of any desired degree of sharpness.

If now a lagging phase shift is introduced into the amplifier, for example, by connecting the capacitor C from grid to earth, it will be seen that the total phase shift due to network and amplifier just below resonance will be greater than 90° and the feedback voltage will have a positive component, whilst above resonance a greater negative component will exist. The effect of this is to unbalance the amplitude characteristic as shown in Fig. 9. A rise in response occurs just before the resonance frequency due to the positive component of feedback, and above the resonant frequency

the response rises to a fraction of its value below resonance and then falls off due to the attenuation produced by the capacitor C.

The addition of a further R-C attenuating network external to the circuit will produce a frequency response characteristic as

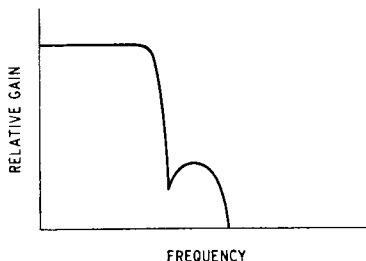

Fig. 10. Final low-pass characteristic resulting from addition of external R-C attenuator.

shown in Fig. 10. The similarity of this curve to the response of a resonant element L-C filter will readily be appreciated. There is a practical limit to the rate of attenuation which can be achieved with a single stage, since the attenuation rate and the level to which the response rises above the frequency of maximum attenuation are interrelated. Thus a high rate of attenuation is achieved with simplicity only at the expense of a low ratio of response below cut-off to peak response above cut-off. However, a rate of attenuation of 40db/octave can be obtained from one stage with a minimum attenuation above cut-off of nearly 30db, which is quite satisfactory. By cascading a number of these filter stages any desired attenuation characteristics may be achieved, and high-pass filters may be similarly formed by the addition of leading phase shift to the amplifier.

A filter designed on these lines, with five switched positions giving nominal cut-off frequencies of 5, 7, 10 and 13kc/s and a "linear" position is incorporated in the final circuit. The performance is shown in Fig. 11.

Gramophone Pre-amplifier.

The arrangements just described are generally all that is necessary to compensate for defects in radio transmissions. For record reproduction, however, additional fixed compensation is required. The nature of this compensation will depend on the recording charac-

teristic and the type of pickup used.

For reasons now too well known to require repetition, lateral disc recordings are usually cut with a groove amplitude which is proportional to signal below some arbitrarily selected frequency in the 300-400 c/s region and with a lateral groove velocity which is proportional to signal above this frequency. To improve signal/noise ratio it is now common practice to increase the level recorded at high frequencies. This is particularly effective, since the noise energy per cycle increases with frequency due to the structure of the record material. In Fig. 12 is shown the recording characteristic used by Decca. The E.M.I. characteristic does not differ substantially at low frequencies but the rise above 3,000 c/s is absent. It is proposed to use the Decca characteristic as a basis for design. When playing E.M.I. recordings, one fixed capacitor in the pre-amplifiers to be described later may be switched out of circuit, giving a level response. Alternatively the gramophone pre-amplifier may be left unchanged and correction provided by means of the variable treble control in the tone compensation unit. This, when C_{20} is set to 100pF and R_{14} (Fig. 5) advanced by one quarter of maximum rotation, gives almost perfect correction.

The majority of pickups, with the exception of piezoelectric types, give an electrical output which is proportional to the lateral velocity of the stylus. The output of such a pickup when playing a Decca recording will be of the form shown in Fig. 12, with ordinates of voltage instead of velocity. A pre-amplifier suitable for such a pickup should have a frequency characteristic which is the inverse of this.

Some desirable properties of a pickup pre-amplifier are:—

1. Low noise level.
2. Low distortion at signal levels likely to be encountered with pickups in common use.
3. Sharp attenuation below 20c/s to suppress turntable rumble, etc.
4. Provision for varying the gain electrically.

Noise Level.—The attainment of a low noise level in high-quality sound systems is of such vital im-

¹ Thiessen, G. J. "R-C Filter Circuits," *Journal of the Acoustical Society of America*, Vol. 16, No. 4, pp. 275-279 April, 1945

The Williamson Amplifier

portance that a few remarks of a general nature will not be out of place at this juncture.

It is an unfortunate fact that improvements in microphones and pickups in the direction of wider frequency range and absence of other forms of distortion are almost invariably achieved at the expense of the electrical output. This does not necessarily mean that the efficiency of the transducer is reduced by the other improvements, but merely that it removes less energy from the record groove or from the record acoustical field or from the record groove which actuates it, causing less disturbance of this field, or less wear of the record groove.

There is, however, a limit to this tendency set by the noise generated by thermal agitation in the transducer and its auxiliaries and by the noise produced in the first valve of the amplifier. It is desirable in a wide-range, high-quality sound system to attempt to maintain a peak signal/noise ratio of at least 70 db. This figure represents the best that can be achieved with a direct cellulose disc recording when everything is "just right," and it is to be expected that the standards of commercial disc recordings will approach this level when improved techniques are combined with new disc materials. A well-designed magnetic tape recorder will give a signal/noise ratio of 70-80 db, and the increasing use of this type of equipment will doubtless give impetus to the research necessary for the achievement of similar standards in other forms of recording. With a signal/noise ratio of 70 db, a sound reproducing system with a frequency re-

sponse flat to 20,000 c/s operating at a realistic volume level produces, in the absence of a signal, noise which is just audible as a very gentle rustle and is completely inoffensive.

Most modern microphones and pickups are electromagnetic, although there is a tendency for microphone design to gravitate towards carrier-operated capacitor types. These have problems of their own and will not be treated here. Electromagnetic microphones and pickups are manufactured with impedances ranging from a few milliohms to several thousand ohms, but are normally used in conjunction with a transformer which raises the impedance to a suitably high value to match the input impedance of a valve.

For obvious reasons it is desirable to make this secondary impedance as large as possible—say

several megohms—since the voltage output from the transducer will increase simultaneously, reducing the gain required from the electronic equipment and the amount of noise contributed by it.

It is not practicable, however, to increase the secondary impedance much beyond 0.1 MΩ if a flat frequency response is required from the transformer over the audible range.

The noise generated by thermal agitation in a 0.1 MΩ resistor at room temperature is about 6 μV for a bandwidth of 20,000 c/s. To this must be added the noise produced in the first valve of the amplifier. By careful design and construction, and by the use of a suitable valve, the noise from all causes, including mains hum, can be reduced to a value equivalent to about 3 μV at the grid, but under normal conditions a figure

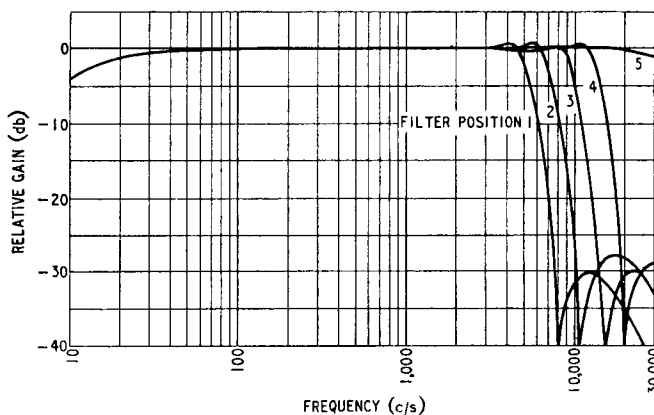

Fig. 11. Measured overall response of low-pass filter, in conjunction with pre-amplifier circuit (Fig. 15, page 26).

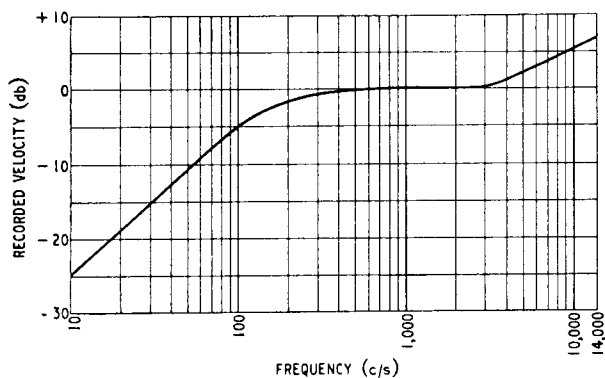

Fig. 12. Decca recording characteristic.

of 5 μV is fairly representative. The total noise may be taken as the square root of the sum of the squares of these values, or about 8 μV. To obtain a signal/noise ratio of 70 db, then, the peak signal must be 70 db above this level, say 25 mV r.m.s. The pre-amplifier should have sufficient gain to enable the main amplifier to be fully loaded by a signal at this level.

The choice of a valve type for the first stage must be made carefully. In theory, for equal gain the noise level in a triode stage is lower than that produced by a pentode, since the pentode has an additional noise component due to

The Williamson Amplifier

electron partition between screen and anode. In fact, however, there are no high-gain triodes commercially available with the requisite characteristics and electrode structures for low-noise operation. A valve designed for such conditions should have a rigidly braced electrode structure to reduce microphony and a balanced "double helical" heater construction to minimize the alternating field surrounding the cathode. The Mullard EF37 has this construction and, connected as a pentode, the noise levels mentioned earlier are obtainable. Before commencing work, the reader who is not familiar with the technique of high-gain amplifier construction should consult an article on this subject.^{2,3} Considerable reduction of residual hum may usually be obtained by demagnetizing the valve.⁴ In order to obtain the best signal/noise ratio, the principle which should be followed, when valve noise is the limiting factor in high-gain amplifiers, is to put the whole of the available signal into the valve grid, and to provide any frequency compensation which may be necessary after the signal has been amplified. By this method valve noise is included in any attenuating operations which may be performed and the overall signal noise ratio is improved.

Low Distortion. — Numerous methods of providing a response which varies with frequency are possible and, of course, each method has advantages and disadvantages. Where the response has to be continuously variable the method which gives greatest simplicity of control usually triumphs. Other things being equal, however, methods which employ selective negative feedback are to be preferred, as circuits of this nature generally have a high signal-handling capacity and non-linear distortion is kept to a minimum. In a pickup pre-amplifier this may be of importance where pickups with widely varying output levels are to be used.

¹ Baxandall, P. J., "Hum in High Gain Amplifiers," *Wireless World*, Vol. 53, No. 2, pp. 57-61, February, 1947.

² Dickerson, A. F., "Hum Reduction," *Electronics*, Vol. 21, No. 12, p. 112, December, 1948.

³ Correspondence, *Electronic Engineering*, Vol. 20, No. 245, p. 235, July, 1948; No. 248, p. 339, October, 1948; No. 250, p. 406, December, 1948.

High - Pass Characteristic. — Gramophone motors tend to produce vibrations which can cause unpleasant rumbling noises in a wide-range system. Although the energy contained in the "rumble" components may be relatively low, the frequency is also very low, and consequently loud-speaker cone movements of high amplitude may be caused. If the driving coil should move out of the region of uniform flux-density, the whole spectrum being reproduced will be distorted in a particularly unpleasant manner. Distortion in the output transformer is also possible.

This situation can be improved materially by the insertion of a high-pass filter with a cut-off frequency of about 20c/s and a fairly rapid attenuation below cut-off. At these low frequencies, such filters are conveniently composed of resistance-capacitance networks and may be incorporated in the bass-compensation pre-amplifier.

Electrical Fading Control. — When the pickup is placed on, or removed from, the disc the gain must be reduced to avoid unpleasant noises. While this may be done by a mechanical potentiometer the method is clumsy and does not facilitate rapid record changing. It has been found convenient to employ an electrical method in which the gain of one of the stages is reduced to zero at the flick of a switch by a bias voltage applied and removed by means of a network with a suitable time constant.

Pre-Amplifiers

Although all the refinements outlined so far are desirable, individual requirements will vary considerably and will determine how much complication should be attempted. Two gramophone pre-amplifier circuits will therefore be described, which should cover most requirements.

Fig. 13 shows a simple circuit which gives good compensation for the Decca recording characteristic. The circuit constants have been adjusted to give as high a degree of attenuation below 20 c/s as is consistent with simplicity. This involves a slight sacrifice of the response at 20 c/s.

The method of operation is as follows: Negative feedback is

applied to the valve by the potential divider formed by R_{34} and the impedance of C_{14} , C_{15} and R_{33} . At medium frequencies the reactance of C_{14} is small, and that of C_{15} large compared with the resistance of R_{33} and R_{34} , and the gain of the stage is determined by the values of these resistors. As the frequency is lowered the impedance of the top limb increases, giving a progressive reduction of feedback. This produces a gain/frequency characteristic which rises to a maximum, determined by the circuit constants, and then decreases due to the coupling components C_{16} , R_{35} and R_{36} . With increasing frequency the impedance of C_{15} decreases, increasing the negative feedback and producing a falling gain/frequency characteristic.

The capacitance between the input transformer secondary winding and earth may, if large, affect the response at the extreme upper end of the audible spectrum. This effect is negligible with a well-designed component, but long leads should be avoided. The transformer should be mounted on the pre-amplifier chassis, which in turn may conveniently be fixed beneath the motor board.

The overall characteristic with an input from a perfect "velocity" pickup on a Decca disc is shown in Fig. 14.

A more complex circuit, which gives nearly perfect compensation and a very rapid attenuation (30db/octave) below 20 c/s, is shown in Fig. 15. This pre-amplifier has a higher gain than the previous one, and is particularly suitable for use in equipment where the pickup is located at some distance from the rest of the amplifier as the circuit terminates in a cathode follower.

The construction of this circuit is not recommended for those without access to facilities for checking the response of the finished unit, as the performance may be seriously affected by an error in component values.

The frequency characteristic of this amplifier is produced by the combination of two curves shown at A and B in Fig. 16. These, when added, give the curve C. Curve A is produced by the circuit associated with V_{13} , which is similar in principle to that of

The Williamson Amplifier

List of Components for Fig. 13.				
	Value to suit	Type	Rating	Tolerance
R ₂₇	transformer	High-stability carbon		
R ₂₈	0.1 MΩ	do.	½ W	
R ₂₉	0.68 MΩ	do.	½ W	
R ₃₀	0.22 MΩ	do.	½ W	
R ₃₁	47 kΩ	do.	½ W	
R ₃₂	4.7 kΩ	do.		
R ₃₃	0.22 MΩ	Composition		10%
R ₃₄	22 kΩ	do.		10%
R ₃₅	2.2 MΩ	do.		
All resistors may be ½ W rating tolerance 20% unless otherwise specified.				
		Type	Rating (V d.c. working)	Tolerance
C ₁₁	0.5 μF	Paper	250	
C ₁₂	50 μF	Electrolytic	12	
C ₁₃	16 μF	Electrolytic	450	
C ₁₄	4000 pF	Silvered mica	350	10%
C ₁₅	100 pF	Silvered mica	250	10%
C ₁₆	0.05 μF	Paper	500	

Fig. 13. Simple gramophone pre-amplifier designed for the Decca recording characteristic. When playing E.M.I. records C₁₅ may be switched out of circuit. Alternatively, compensation can be effected in the tone-control circuits.

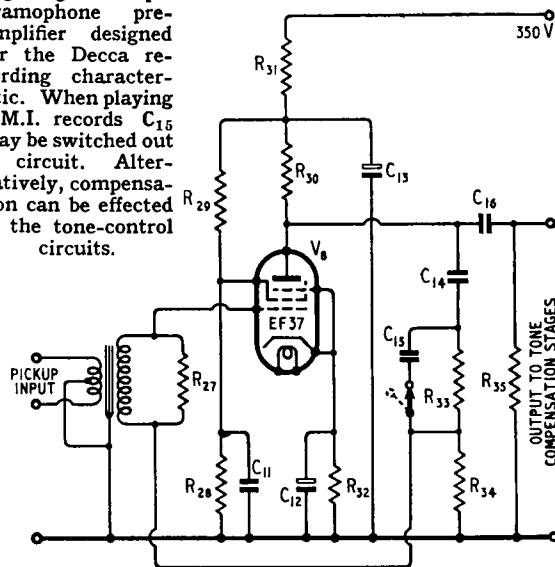

Fig. 13. The attenuation at low frequencies is due to the combined effect of the intervalve couplings. Curve B is produced by feedback over V₁₄ through a parallel-T network tuned to 20 c/s.

The overall frequency response curve, taken under the same conditions as that of Fig. 14, is shown in Fig. 17.

Fading Control.—The circuits of Figs. 13 and 15 have no provision for electrical fading. Fig. 18 shows a network which, when connected to the cathode of V₆ in Fig. 13 or V₁₃ in Fig. 15, enables the gain to be reduced to zero in about a second when the switch S₅ is closed. On opening S₅ the gain is restored to its normal value in a similar period.

Complete Variable Compensation Unit.—It is now necessary to connect together the circuits just described to form a flexible tone compensation unit. This must be done in such a manner that each works well within its signal-handling capacity and does not influence the others adversely. Fig. 19 on pages 28 and 29 shows the final arrangement.

Power Supplies.—The High Quality Amplifier has a frequency response which is useful down to 2 c/s. This necessitates a few precautions when auxiliaries are connected to the input. At these very low frequencies, the balance of the push-pull stages may not be good, and there may be considerable signal in the supply line.

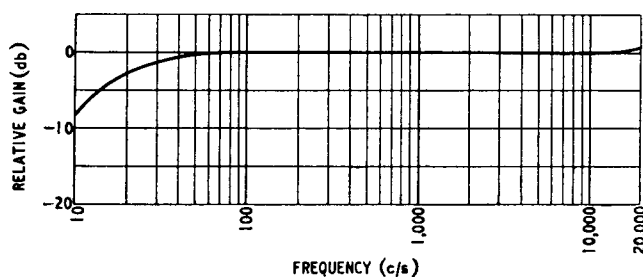

Fig. 14. Response curve of circuit of Fig. 13 with ideal "velocity" pickup.

A very carefully designed and necessarily expensive decoupling system is required if a high-gain pre-amplifier is to operate satisfactorily from the amplifier power supply. The cost of such decoupling is higher than that of a separate power supply unit producing, say, 350 V at 20 mA, and therefore the use of a unit of this type is strongly recommended.

Performance.—Frequency Response.—Reference to Figs. 6, 11, 14 and 17 will enable the frequency response of any combination of units and control settings to be determined. The effect of intermediate control settings may be arrived at by interpolation.

Gain.—The figures underlined in Fig. 19 are the peak signal voltages necessary to give maximum output at 1,000 c/s when the pre-amplifier is used in conjunction with the High Quality Amplifier.

The simple pickup pre-amplifier

(Fig. 13) has a gain of 11 at 1,000 c/s. Thus, when this unit is used, full output may be obtained with a pickup which produces 18 mV peak. Should it be required to use the system with an insensitive microphone, disconnection of C₁₄ in Fig. 13 will raise the gain of the stage to about 150, with a sensibly linear frequency response. Full output will then be obtained with an input of 1.3 mV peak. The more complex pickup pre-amplifier (Fig. 15) has a gain of approximately 250.

Noise Level.—With careful construction and by adjustment of R₅₇ to give minimum hum, the noise level may be reduced to an equivalent input signal of 3.5 μV at the pickup pre-amplifier grid, excluding the noise due to the pickup transformer and auxiliaries.

Distortion.—The total harmonic distortion produced by the units when used up to the signal

The Williamson Amplifier

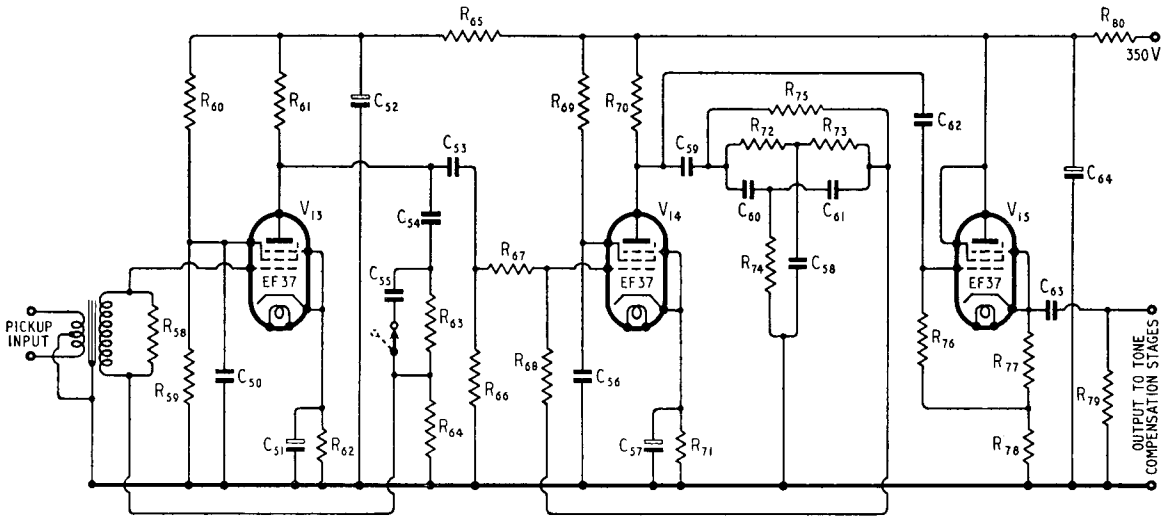

Fig. 15. Pre-amplifier with high-pass filter.

Component Values for Circuit of Fig. 15.

		Type	Rating Tolerance				Type	Rating	Tolerance
R ₅₈	Value to suit transformer	High-stability carbon			R ₇₉	0.22 MΩ	Composition		20%
R ₅₉	0.1 MΩ	do.	½W	20%	R ₈₀	10 kΩ	do.	1W	20%
R ₆₀	0.68 MΩ	do.	½W	20%	* May require adjustment.				
R ₆₁	0.22 MΩ	do.	½W	20%	All resistors may be ¼W rating, except where otherwise stated.				
R ₆₂	4.7 kΩ	do.		20%					
R ₆₃	0.22 MΩ	Composition		10%					
R ₆₄	20 kΩ*	do.							
R ₆₅	22 kΩ	High-stability carbon	½W	20%	C ₅₀	0.5 μF	Paper	250	20%
R ₆₆	0.22 MΩ	Composition		10%	C ₅₁	50 μF	Electrolytic	12	
R ₆₇	0.20 MΩ*	do.			C ₅₂	16 μF	Electrolytic	450	
R ₆₈	4.7 MΩ	do.		5%	C ₅₃	0.02 μF	Paper	350	10%
R ₆₉	1.0 MΩ	do.	½W	20%	C ₅₄	4000 pF	Silvered mica	350	10%
R ₇₀	0.22 MΩ	do.	½W	20%	C ₅₅	100 pF	Silvered mica	350	10%
R ₇₁	2.2 kΩ	do.		20%	C ₅₆	0.5 μF	Paper	250	20%
R ₇₂	2.0 MΩ	High-stability carbon		1%	C ₅₇	50 μF	Electrolytic	12	
				or matched	C ₅₈	0.01 μF	Silvered mica	350	1%
R ₇₃	2.0 MΩ	do.		1%					or matched
				or matched	C ₅₉	0.25 μF	Paper	500	20%
R ₇₄	1.0 MΩ	do.		1%	C ₆₀	5000 pF	Silvered mica	350	1%
				or matched					or matched
R ₇₅	10 MΩ	Composition		5%	C ₆₁	5000 pF	Silvered mica	350	1%
R ₇₆	47 kΩ	do.		10%					or matched
R ₇₇	1 kΩ	do.		20%	C ₆₂	7000 pF	Silvered mica	350	10%
R ₇₈	47 kΩ	do.	1W	20%	C ₆₃	0.5 μF	Paper	500	20%
					C ₆₄	16 μF	Electrolytic	450	

levels indicated is considerably less than 0.1 per cent.

Form of the Equipment.—The outward form which a complete domestic sound equipment takes is very much a matter of personal taste. The suggestions which follow have been found in practice to provide ease of operation combined with absence of troublesome feedback effects.

The equipment is best constructed in two units, one containing the loudspeaker and the

other the turntable. This prevents mechanical and acoustical feedback.

The control unit may be a console of armchair height (overall dimensions about 18in × 14in × 20in high) easily movable on castors. This may contain the pickup and turntable, the pre-amplifier unit and, if desired, a radio receiver, complete with its power supply. The output from the pre-amplifier may be connected via a cathode follower to

a multicore-screened cable, which connects the console with the amplifier and loudspeaker unit, and carries the mains and aerial connections.

The amplifier and loudspeaker unit may be a triangular corner cabinet, with the amplifier built into the lower portion, and the loudspeaker occupying the upper section, arranged at a convenient level for listening.

This arrangement gives great ease of manipulation, avoiding

the necessity of rising from one's comfortable seat to attend to the controls or change a record. The main amplifier may be included in the console, but this tends to make it heavy and bulky, and gives rise to problems of heat dissipation which are not easily solved.

Acknowledgment.—The writer is greatly indebted to Ferranti, Ltd., for permission to publish the results of work undertaken on their behalf, and wishes to thank his colleagues for help freely given.

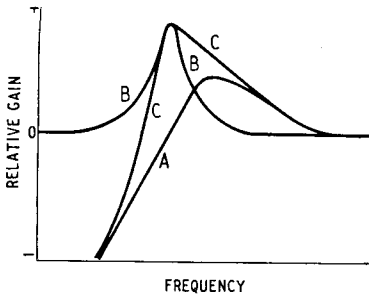

Fig. 16. Derivation of high-pass characteristic.

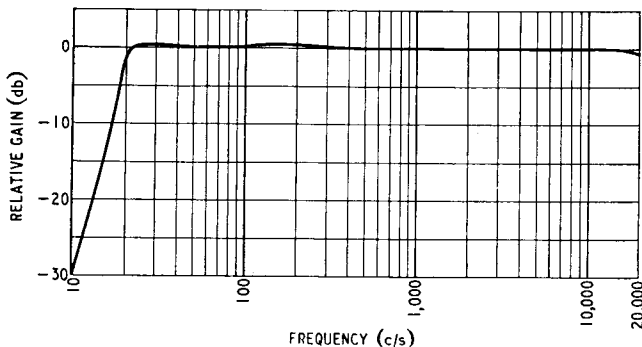

Fig. 17. Response curve of circuit of Fig. 15.

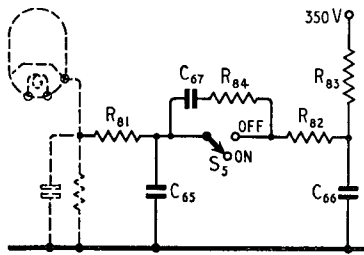

Fig. 18. Circuit of fading control.

List of Components for Fig. 18.

		Rating
R ₈₁	0.22 MΩ	½W
R ₈₂	0.22 MΩ	½W
R ₈₃	47 kΩ	
R ₈₄	100Ω	

All resistors may be ½W rating, tolerance 20% unless otherwise specified.

		Rating (V.d.o. working)
C ₆₅	4 μF	250
C ₆₆	2 μF	350
C ₆₇	0.1 μF	350

WILLIAMSON'S O.P. TRANSFORMER

To Author's
Specification

£4-13-6

CHOKES FOR WILLIAMSON'S AMPLIFIER

30H at 20 m/a. . .	18/6
10H at 150 m/a. . .	35/6
50H at 20 m/a. . .	22/-

MAINS TRANSFORMERS

FS43. Input 200/250v.
Output 425/0/425v. at
200 m/a. 6.3v. 4 amps.
C.T. 6.3v. 4 amps. C.T.
5v. 3 amps.
Fully Shrouded 51/-

W.I. Input 200/250v.
Output 325/0/325v. at
20 m/a. 6.3v. 0.6 amps.
6.3v. 1.5 amps. Chassis
mounting 23/-

H. ASHWORTH

676, GREAT HORTON
ROAD

BRADFORD YORKS.

'Phone: BRADFORD 71916

OTHER "WIRELESS WORLD" REPRINTS

Receiver Alignment Equipment: 1. Simple Cathode-Ray Oscilloscope (March 1950). 2. Design for a Wobulator (October 1950). By M. G. Scroggie, B.Sc., M.I.E.E. 9d. net. By post 10½d.

Communications Receiving Equipment: 1. Ex-R.A.F. Communications Receiver (July 1946). 2. Band-Pass Converters (October 1950). 3. More about Band-Pass Converters (February 1951). 4. 21 m/cs Band Pass Converter (July 1952). 1s. net. By post 1s. 1½d.

Radio Feeder Unit: High Quality Pre-tuned Receiver with Gramophone Pre-amplifier. By J. F. O. Vaughan (December 1951). 9d. net. By post 10½d.

Television Oscilloscope: Simple Design with Five-Inch Cathode Ray Tube. By W. Tusting (June and July 1952). 9d. net. By post 10½d.

Midget Three-Valve A.C. Mains Receiver: Long and Medium Wave T.R.F. set. By S. W. Amos, B.Sc. (HONS.) (February 1950). 6d. net. By post 7½d.

Sensitive T.R.F. Receiver: Embodying Automatic Gain Control. By S. W. Amos, B.Sc. (HONS.) and G. G. Johnstone B.Sc. (HONS.) (October and November 1951). 1s. net. By post 1s. 1½d.

Obtainable direct from:

ILIFFE & SONS LTD., DORSET HOUSE, STAMFORD ST., LONDON, S.E.1.

The Williamson Amplifier

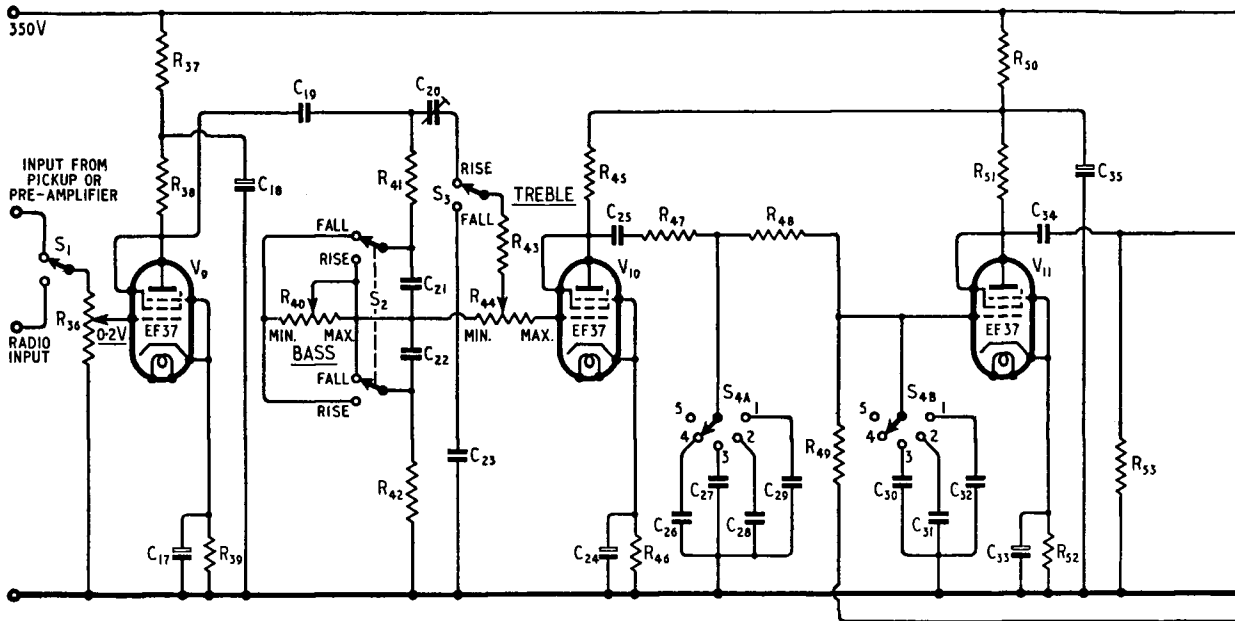

Fig. 19. Complete tone compensation and filter unit. The input and output voltages underlined are peak values for full output from the main amplifier.

List of Components for Fig. 19.

Component	Value	Rating	Tolerance	Type	Rating (V d.c. working)	Tolerance
R ₃₆	0.25 MΩ log.					
R ₃₇	47 kΩ	1W				
R ₃₈	47 kΩ	1W				
R ₃₉	3.3 kΩ					
R ₄₀	0.25 MΩ log.					
R ₄₁	100 kΩ					
R ₄₂	6.8 kΩ					
R ₄₃	10 kΩ					
R ₄₄	0.1 MΩ linear					
R ₄₅	100 kΩ	1W				
R ₄₆	2.2 kΩ					
R ₄₇	0.1 MΩ		10%			
R ₄₈	0.47 MΩ		10%			
R ₄₉	0.47 MΩ		10%			
R ₅₀	33 kΩ	1W				
R ₅₁	100 kΩ	1W				
R ₅₂	3.3 kΩ					
R ₅₃	1 MΩ					
R ₅₄	0.1 MΩ	High-stability carbon	or matched			
R ₅₅	0.1 MΩ			1%		
R ₅₆	50 kΩ			1%		
R ₅₇	100 Ω					
C ₁₇	50 μF	Electrolytic			12	
C ₁₈	8 μF	Electrolytic			450	
C ₁₉	0.25 μF	Paper	20%		500	
C ₂₀	150 pF max.	Preset				
C ₂₁	0.01 μF	Paper	20%		250	
C ₂₂	0.05 μF	do.	20%		250	
C ₂₃	1000 pF	Silvered mica	20%			
C ₂₄	50 μF	Electrolytic			12	
C ₂₅	0.05 μF	Paper	20%		500	
C ₂₆	100 pF	Silvered mica				5%
C ₂₇	200 pF	do.				5%
C ₂₈	300 pF	do.				5%
C ₂₉	500 pF	do.				5%
C ₃₀	50 pF	do.				5%
C ₃₁	100 pF	do.				5%
C ₃₂	250 pF	do.				5%
C ₃₃	50 μF	Electrolytic			12	20%
C ₃₄	0.05 μF	Paper			500	
C ₃₅	8 μF	Electrolytic			450	
C ₃₆₋₄₀	75 pF	Silvered mica				1% 1% 1% 1% 1%
C ₃₇₋₄₁	100 pF	do.				
C ₃₈₋₄₂	150 pF	do.				
C ₃₉₋₄₃	200 pF	do.				
C ₄₄	150 pF	do.				
C ₄₅	200 pF	do.				
C ₄₆	300 pF	do.				
C ₄₇	400 pF	do.				
C ₄₈	16 μF	Electrolytic			450	
C ₄₉	16 μF	do.			500	

All resistors may be 1/4W rating, tolerance 20% unless otherwise specified.

Choke.

CH₃ 50H at 20 mA. Resistance about 1,500 Ω.

Mains Transformer.

Primary : 10-0-200-220-240 V, 50 c/s.
 Secondaries : 1. 325-0-325 V, 20 mA d.c.
 2. 6.3 V, 0.6 A.
 3. 6.3 V, 1.5 A.

Switches.

S₁. Single pole double throw.
 S₂. Double pole double throw.
 S₃. Single pole double throw.
 S₄. 5 bank, 5 position selector switch.

The Williamson Amplifier

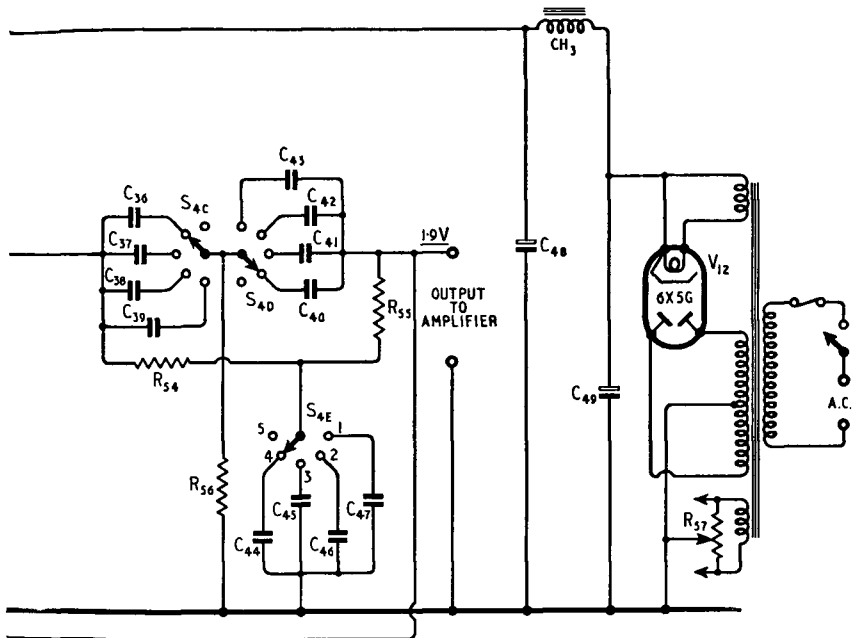

Radio Feeder Unit (see page 30 for general details)

ADDITIONAL COIL DATA

The radio feeder unit described on succeeding pages was designed originally to provide high-quality reception from medium-wave stations and coil-winding data covered a range of frequencies from 500 kc/s to 1.6 Mc/s.

Since then there have been many requests for guidance in the con-

struction of coils for the reception of the Droitwich transmitter on 200 kc/s, and the author has supplied the following additional data for those who get a higher signal strength for the B.B.C. Light Programme from the long-wave transmitter.

COIL-WINDING DATA FOR THE LONG-WAVE RANGE

Transformer	Winding	No. of turns	Inductance (μH)	Coefficient of coupling (approx.)
Aerial	Primary	180	750	0.3
	Secondary	330	2,000	
Coupling	Primary	260	1,500	0.6
	Secondary	330	2,000	

Coils are wound with 40-42 s.w.g., d.s.c. copper wire.

To give the correct coefficient of coupling the spacing between the windings of the aerial transformer should be increased to 0.25in. The disposition of the coupling transformer windings is unaltered.

When continuous tuning is to be

used, the minimum capacitance of the ganged capacitor should be increased by the addition of a 100pF silvered-mica capacitor across each secondary winding of the transformers, giving a coverage of approximately 150-300 kc/s.

For fixed tuning, the capacitors should be 300 pF.

THE WILLIAMSON AMPLIFIER DESERVES JOINTS SOLDERED WITH



One imperfectly soldered joint may endanger the successful assembly of the Williamson Amplifier. Solder with Multicore and run no risks. Multicore contains 3 cores of extra-active, non-corrosive Ersin Flux ensuring speedy and reliable soldering without waste or trouble and guaranteeing that there are no lengths of solder without flux. Correct proportions of both flux and solder are automatically applied. Fast-acting, fast-holding Multicore is used exclusively by leading manufacturers of radio, T/V and electronic equipment. Make certain of a good job—with Multicore.

THE SIZE 1 CARTON (shown above) has been designed specifically for easy use. Simply pull out the length you require. C16018 specification (60/40 alloy) is particularly recommended for the Williamson Amplifier

RADIO & T/V SERVICE ENGINEER'S 1 lb. REEL.

For uses which demand fair quantities of solder. Contains approximately 167 feet of 18 S.W.G. 50/50 alloy Ersin Multicore Solder.



Ersin Multicore Solder can be obtained from radio shops everywhere. Size 1 carton 5/- retail. 1 lb. reel 15/-.

MULTICORE SOLDERS LTD.
MULTICORE WORKS, MAYLANDS AVENUE,
HEMEL HEMPSTEAD, HERTS (BOXMOOR 3636)

Design for a Radio Feeder Unit

THE preceding articles in this series have described amplifier, tone compensation and gramophone pre-amplifier units which are capable of driving a loudspeaker from the output of a pickup or a radio receiver. The design of a radio receiver which would be suitable for use under the varied reception conditions which exist in the populous parts of the country, and which at the same time could be constructed simply and with certainty of results, would be a difficult undertaking. In addition, such a receiver would be unnecessarily complex for the needs of that section of the community which lives within the primary service area of high-powered twin-wave

transmitters, and which desires only to receive transmissions from these by the simplest possible means.

In order that the units described in the series should form a complete domestic sound installation, it is proposed to outline the design of a small two-stage receiver suitable for the reception of medium-wave transmissions within the primary service area. The type of receiver to be described gives satisfactory results where the spacing between the carrier frequencies of the principal transmitters is high, say 200 kc/s. It is not suitable for use in districts where closely-spaced powerful transmissions exist, or where interference is severe. The receiver circuit is

offered as an indication of the general lines on which to proceed, and is capable of being adapted to individual requirements and conditions.

The basic circuit, shown in Fig. 20, consists of an r.f. amplifier, transformer-coupled to a negative-feedback detector. Circuit values for a number of alternative tuning arrangements are given. Possibly the simplest scheme, from the point of view of construction, is to use a twin-ganged capacitor to cover the range, although by this method it is not easy to secure a uniformly good performance at each end of the medium-wave band. Alternatively the receiver may be pre-tuned, stations being selected by a

Fig. 20. Circuit diagram of local station radio receiver. Positions of selector switches for pre-set tuning shown at X.

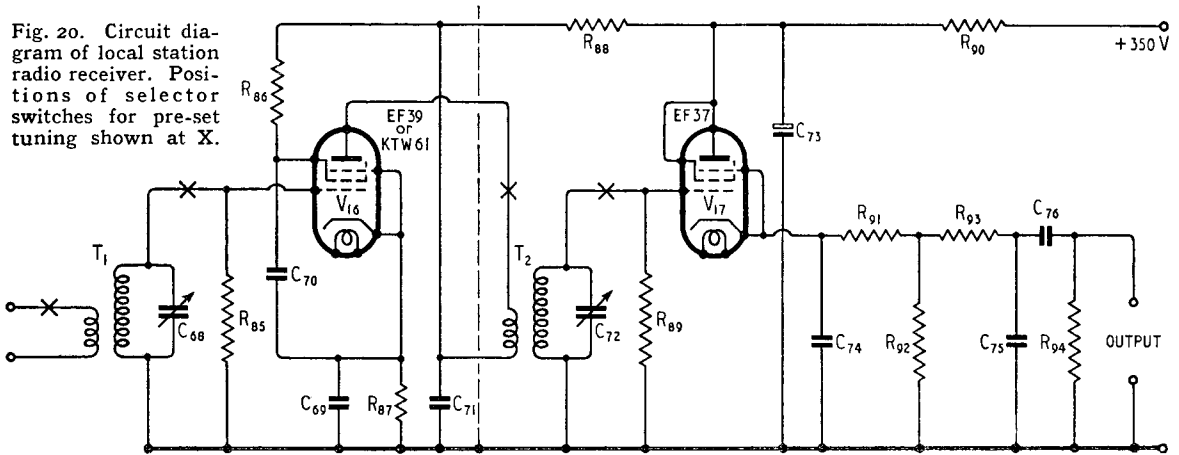

COMPONENT VALUES FOR CIRCUIT OF FIG. 20

	Rating		Type	Rating (V d.c. working)
R ₈₅	0.1 MΩ			
R ₈₆	0.1 MΩ	½ W		
R ₈₇	330 Ω			
R ₈₈	1.5 kΩ			
R ₈₉	0.1 MΩ			
R ₉₀	10 kΩ	2 W		
R ₉₁	47 kΩ			
R ₉₂	4.7 kΩ			
R ₉₃	22 kΩ			
R ₉₄	2.2 MΩ			
All resistors may be ½ W rating, tolerance 20 per cent unless otherwise specified.				
C _{68, 72}	See text			
C ₆₉	0.1 μF		Paper	250
C ₇₀	0.1 μF		Paper	350
C ₇₁	0.1 μF		Paper	350
C ₇₃	16 μF		Electrolytic	450
C ₇₄	100 pF		Silvered mica	
C ₇₅	100 pF		Silvered mica	
C ₇₆	0.1 μF		Paper	500

The Williamson Amplifier

push-button or rotary switch. The use of variable inductors in this arrangement provides a simple method of achieving a uniform selectivity and sensitivity over the range, with the disadvantage that two coils or tuned circuits must be provided for each station to be received. In the unlikely event of serious thermal drift, correction is easily applied by the use of negative temperature coefficient capacitors.

R.F. Transformers.—Winding data are given to enable r.f. transformers to be wound simply on standard formers without the use of a wave-winding machine. The correct number of turns are piled in a random manner between thin Paxolin or cardboard cheeks, which serve to guide and support the edges of the winding. This gives an approximation to the performance of a wave-wound coil.

The table gives winding data for transformers to be used with a twin-ganged capacitor with a capacitance swing of 485 pF with trimmers, covering a frequency range of approximately 550-1,550 kc/s.

When separately-switched tuned transformers are to be used, the values of secondary inductance and tuning capacitance may be read from the curve of Fig. 21 against transmitter frequency. This curve has been computed for an L/C ratio of unity (L in μH , C in pF), which is nearly optimum. The number of turns necessary to produce the required inductance with the formers and dust-cores specified may then be obtained from Fig. 22. The

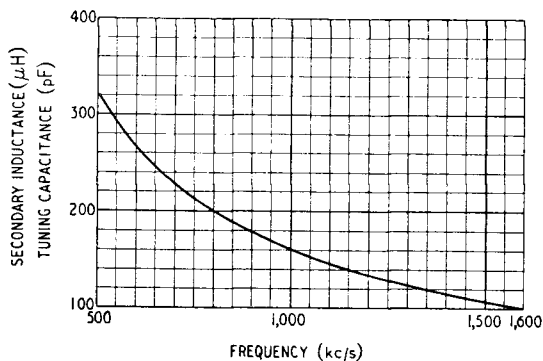

Fig. 21. Curve relating tuned circuit parameters and resonance frequency.

WINDING DATA FOR R.F. TRANSFORMERS

Transformer	Winding	No. of turns	Inductance (μH)	Coefficient of coupling (approx.)
Aerial	Primary	35	30	0.35
	Secondary	95	160	
Coupling	Primary	60	80	0.65
	Secondary	95	160	

dimensions of the coil formers and windings are shown in Fig. 23. When the capacitance is being chosen, allowance should be made for strays, which will probably be about 25 pF. The values used should therefore be less than those indicated by this amount. In practice the nearest standard value should be chosen and allowance made in the value of inductance. Movement of the core will enable a variation of approximately ± 18 per cent to be made in the inductance.

Construction.—In order to preserve stability, precautions must be observed when constructing the receiver. The most likely cause

of instability is the presence of undue stray capacitance between the anode and control grid of V_{16} . The valve types used have an anode-grid capacitance of less than 0.003 pF, and a layout should be chosen which does not materially increase this figure. The design, based on this value, has a factor of safety of about 4. Although the valve is metallized, a screening can may be necessary to reduce leakage to the valve base. All components in the grid circuit should be kept above the chassis, and all components in the anode circuit below the chassis. Where components in the anode circuit, or in the following grid circuit

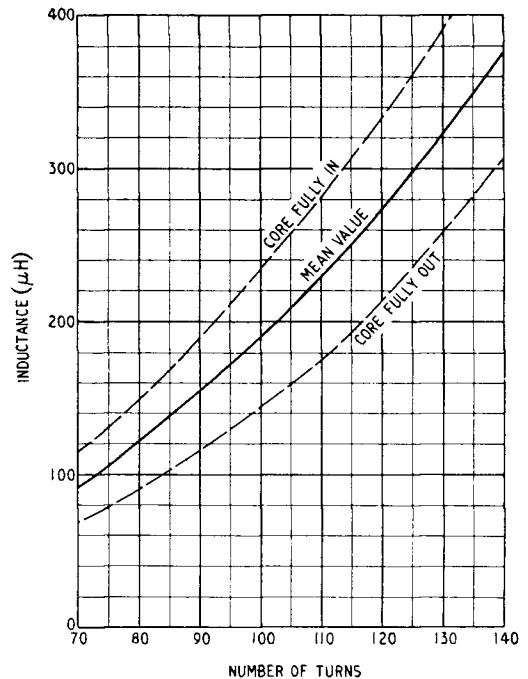
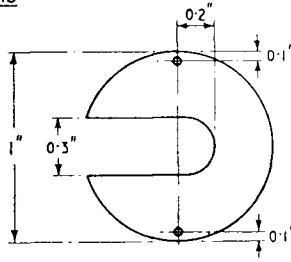
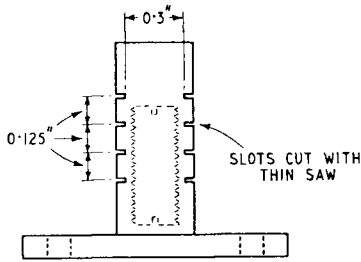

Fig. 22. Curve relating inductance and number of turns for windings discussed in text.

The Williamson Amplifier

COIL FORMERS



MATERIAL: 0.015" BAKELIZED FABRIC OR PAXOLIN

AERIAL TRANSFORMER

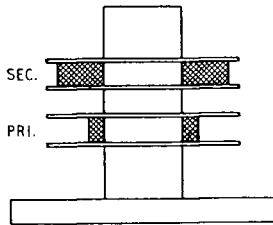

COUPLING TRANSFORMER

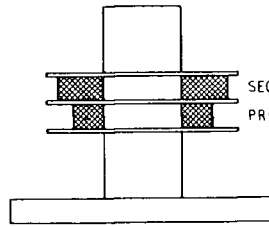

DATA FOR FIXED TUNING

PRIMARY WINDING. (DIRECT AERIAL CONNECTION)
 $\frac{1}{3}$ NUMBER OF SECONDARY TURNS
 PRIMARY WINDING. (70Ω FEEDER)
 $\frac{1}{10}$ NUMBER OF SECONDARY TURNS
 SECONDARY WINDING. SEE TEXT

PRIMARY WINDING.
 $\frac{2}{3}$ NUMBER OF SECONDARY TURNS
 SECONDARY WINDING. SEE TEXT

Fig. 23. Formers are standard moulded type, fitted with 8-mm threaded iron-dust cores. All coils are wound with Litz wire consisting of 7-9 strands of 45-48 s.w.g. enamelled copper wire.

must be brought above the chassis, as is the case when tuning is by means of a ganged capacitor, they must be screened carefully from the aerial circuits. Figs. 24 and 25 show suggested layouts for continuously variable and switched tuning arrangements.

The Detector.—To give low distortion, the detector requires to work at a fairly high signal level—say 5V r.m.s. output. As the receiver is intended to feed the tone compensation unit, which requires an input of only 200 mV peak, the output is taken from a tapping on the detector load resistance. This greatly reduces the a.c. loading on the detector and enables it to handle high modulation levels without distortion.

Alignment Procedure.—(1) Set ganged capacitor at a position about five degrees from the minimum capacitance end, and adjust trimmers for maximum output from the high-frequency Third Programme.

(2) Set capacitor about twenty degrees from maximum capacitance position and adjust dust-cores for maximum output from the low-frequency Third Programme.

(3) Repeat this process until both stations are accurately tuned.

Power Supplies.—The receiver is intended

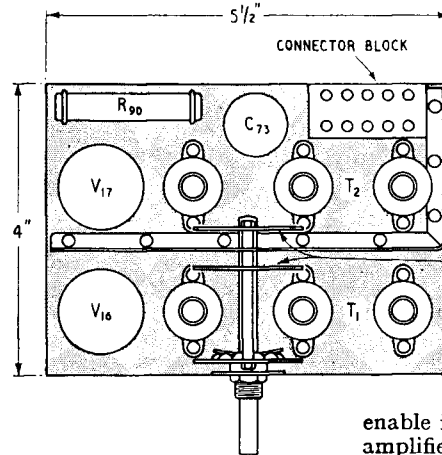
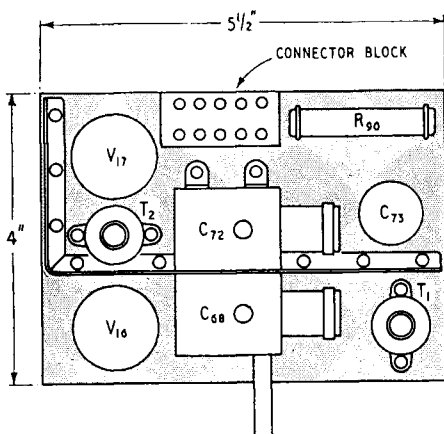

ALUMINIUM OR COPPER SCREEN EXTENDING BELOW CHASSIS AND $3\frac{3}{4}$ " ABOVE CHASSIS WITH CUTOUT FOR GANGED CAPACITOR

CHASSIS $1\frac{1}{2}$ " DEEP

Fig. 24. This diagram shows a plan view of top of chassis.

Fig. 25. Plan view of top of chassis. Switched model.

to be supplied from the pre-amplifier power supply. The decoupling is not adequate to enable it to be fed from the main amplifier supply.

Acknowledgment.—The writer is indebted to Mr. A. T. Shepherd of Ferranti, Ltd., for his assistance in the compilation of data for these notes.



It gives us great pleasure to announce our latest output transformer for the "Williamson" amplifier. The result of some painstaking research, this instrument represents quite a considerable advance on our 2B36B. Typical technical details are as follows:

Primary

D.C. Resistance $90\Omega + 90\Omega$.
 Incremental inductance taken at 5 v. 50 c/s., 100 hys. minimum.
 Nominal impedance $10,000\Omega$ centre tapped.
 Leakage reactance tested at 1 v. 800 c/s.:

Whole Primary to the secondary connected for 30Ω and short-circuited, 16 m/Hys. Insertion loss 0.5 d.b. ($6\frac{1}{2}$ per cent.).

Half primary to the 30Ω secondary, 8 m/Hys.

Half primary to the other half short-circuited, 17 m/Hys.

Secondary

Considerable thought has been given to the question of secondary impedances, and we have decided that, for Loudspeaker matching, the most useful range is given by a basic impedance of 0.45Ω .

The arrangement of secondary sections is, so far as

we know, unique and permits of seven different secondary impedances with virtually no change in leakage reactance as against the normal four obtained with customary arrangements of eight sections.

In the 3C67A these impedances are 0.45Ω , 1.8Ω , 4Ω , 7Ω , 11Ω , 16Ω and 30Ω . One additional impedance— 22Ω —can be obtained if required with an increase in leakage reactance of about 10 per cent.

Frequency Response

With no feedback and assuming a generator impedance of $2,500\Omega$ the frequency response, even at incremental levels, is virtually flat (0.25 d.b.) from $12\frac{1}{2}$ c/s. to 25 kc s. There is a smooth high frequency "roll off" with no objectionable resonances.

Power handling capacity

At 15 watts at $12\frac{1}{2}$ c/s., the core material is being worked at 10,000 gauss and the distortion introduced by the iron at this frequency and power level *without any feedback* should not exceed 2.5 per cent.

At 25 ~ the transformer will handle 60 watts with half this distortion, and in either case quite a modest amount of feedback will reduce the distortion to negligible proportions.

" outstanding results "

" . . . As Mr. Williamson himself observes in one of his *Wireless World* articles, the output transformer is probably the most critical component in a high-fidelity amplifier. Your transformer performs this exacting duty with full honours, and I shall always recommend its use to anyone undertaking construction of a "Williamson." With many thanks for a first-class job."

E. L. J., Swindon.



NURSTEED ROAD · DEVIZES · WILTS

Telephone: Devizes 536

Replies to Queries

Raised by Constructors

THE series of articles recently published on the High-Quality Amplifier has aroused considerable interest and given rise to correspondence.

It is hoped that these notes, which deal with matters of general interest arising from the correspondence, may be of assistance to readers who have similar difficulties.

Valves.—There is no exact equivalent for the Osram type KT66, and its use is recommended where possible. When the equipment is to be used overseas, the KT66 may be difficult to obtain, and 6L6 glass and metal types may be regarded as direct replacements, with the proviso that the total anode and screen dissipation should be reduced from 25 W to 21.5 W by reducing the total current from 125 mA to 110 mA by adjustment of R_{21} . The use of these valves with reduced rating entails a slight reduction of the maximum output. The 807 may be used at the full rating of 25 W, with modifications to the valve connections.

Since the articles were written, a modification of the EF37 has appeared under the number EF37A. This has improved heater construction giving greater freedom from hum, and its use may be advantageous for V_8 and V_{13} .

No other changes in valve types can be recommended, as their use would involve radical redesign.

Output Transformer.—When assembling the core of the transformer, care should be taken to ensure that the edges of the T and U laminations butt together. The magnetic properties of the core are dependent upon careful assembly and tight clamping.

Static Balancing.—The method of balancing the standing currents in the output valves, which was suggested in the article in the August, 1949, issue, is dependent for its success on close matching of the d.c. resistances of the halves of the output transformer primary. Nominally the sections are identical, and when carefully machine-wound from the same reel of wire, the resistances should not differ materially. It is possible, however, due to variations in wire diameter and insulation thickness, for the resistances to differ by up to 5 per cent and even, in extreme cases, 10 per cent. Should this occur, a compensating resistor should be added in series with the low-resistance side in order to equalize the resistances, and the meter connected across the equalized sections.

Other more direct methods may, of course, be used

to adjust the anode currents to equality, but unless the transformer has a split primary winding they are inconvenient, and great care should be taken to ensure that the insertion of instruments does not cause oscillation which could give misleading readings.

Construction.—There is little to add to the constructional data on the main amplifier given in the August, 1949, issue, except perhaps to explain that the purpose of the sub-chassis screen, shown in Fig 3 (see page 15), is to prevent feedback from the anode connections of the output valves to the input of the amplifier. It should extend downwards to the full depth of the chassis.

The method of construction of the preamplifier and tone-compensation units will usually be adapted to individual circumstances. One suggested method of construction for the preamplifier circuit of Fig. 15 is to use a shallow chassis about $9\text{in} \times 3\text{in} \times 1\text{in}$. The valves and electrolytic capacitors are mounted in a group along the centre of this chassis, and the other components mounted vertically above the chassis on tag strips arranged on each side of the central group. The connections to the valveholders are taken through slots cut in the top of the chassis. The input transformer should be mounted on the top of the chassis at one end. With the sizes given, there is ample room for a screened component of dimensions up to $3\text{in} \times 3\text{in} \times 2\text{in}$. The whole unit should be fitted with screening covers, and mounted on the underside of the motorboard as close as possible to the pickup.

The tone compensation unit of Fig. 19 may be constructed on orthodox lines, the only essential being to provide sufficient frontal area to accommodate seven controls. Grid leads should be kept short to avoid hum pick-up. The blank valveholder terminals (pin 6) should *not* be used as anchors for the leads to the top-cap grids. The power supply components can, with advantage, be assembled on a separate chassis.

Conclusion.—The circuits published in the series have been evolved over a considerable period of time and are capable of giving a very high standard of performance. Requests have been received for data on modifications, but as it is rarely possible to determine the full effect of these without carrying out tests, in general, no such data can be supplied by the writer.*

* Or, for that matter, by *Wireless World*.—ED.

RADIO VALVE DATA

Characteristics of 2,000 Receiving Valves and C.R. Tubes

3rd Edition. Compiled by the staff of WIRELESS WORLD. Gives the main characteristics and base connections of over 2,000 types of British and American radio valves, and over 150 cathode-ray tubes. These are further classified into obsolete, replacement or current types as recommended by the makers. 80 pp. 3s. 6d. net. By post 3s. 10d.

Obtainable from all booksellers or direct from:

ILIFFE & SONS LTD., DORSET HOUSE, STAMFORD ST., LONDON, S.E.1.

Modifications for High-impedance Pickups and Long-playing Records

THE introduction of long-playing records in Great Britain, after the publication in November, 1949, of gramophone pre-amplifier circuits for the "High Quality Amplifier" which were suitable only for the 78-r.p.m. standards, has made it necessary to revise these designs.

The principle of recording with a rising frequency characteristic at high frequencies and reproducing with a correspondingly falling characteristic, in order to effect a reduction in the level of surface-noise from the material, is a well-established and useful one. In the case of long-playing records it results, in conjunction with the use of a homogeneous plastic for the record material, in an almost silent background.

There are, however, dangers attendant upon its use. The scheme is based on the hypothesis that the energy level of music decreases with increase of frequency above about 500 c/s. Thus it should be possible steadily to increase the gain of the recording channel above this frequency. This appears particularly attractive at first sight, since with the normally used constant-velocity characteristic the recorded amplitude for a constant recording level is inversely proportional to frequency and is therefore very small at high frequencies.

Initially, a rising frequency response characteristic producing practically constant amplitude at constant level was used, the energy level distribution being relied upon to restrict the amplitude at high frequencies. The effect of this was, in practice, to cancel the improvement in tracing, which the small-groove system offered, by producing, at high frequencies and high orchestral levels, recorded waveforms with radii of curvature too small to be traced accurately. The resulting distortion manifested itself as a tearing sound superimposed on the full orchestra.

There is additional evidence to suggest that the original hypothesis required revision, since it is demonstrable that it breaks down when such percussion instruments as cymbals and castanets are considered, particularly when the frequency range is wide. Indeed, the peak power level required to reproduce cymbals exceeds that normally required at medium frequencies.

This early experience has led to the adoption of a characteristic which is a better compromise between these conflicting factors and gives much more satisfactory results in practice. Fig. 26 shows the provisional recording characteristic now in use by the Decca Record Company for L.P. records. The amount of treble boost is lower than the theoretical optimum, but the use of even this amount of compensation

means that the first stages of the pre-amplifier must be capable of handling occasional high-frequency peaks which are greater than those experienced with standard records, unless the pick-up is a constant amplitude one, or its output at high frequencies is attenuated before reaching the pre-amplifier.

The original designs of pre-amplifier employed negative-feedback methods of compensation, and hence are particularly suitable for a wide range of inputs. However, pickups are available with such a wide variety of output levels that no single circuit will cope adequately with them, and external attenuators may have to be used.

Modifications.—Dealing first with the single-valve pre-amplifier (original circuit, Fig. 13, p. 25), the revised circuit of Fig. 27 shows the modifications necessary to provide alternative standard and long-playing characteristics. To simplify the switching, by using a single-pole changeover switch, the capacitor C_{15} is left permanently in circuit, giving a Decca 78-r.p.m. characteristic in the "78" position. Alternatively, C_{15} may be removed to give the E.M.I. characteristic. In either case, correction for the other 78-r.p.m. characteristic may be made by means of the treble control on the tone compensation unit.

The advantage of this simplified switching is that it becomes practicable to gang the switch to the motor speed-change control to give automatic compensation. If this arrangement is not desired, a two-pole multi-position switch may be used, to give three or more combinations, as in Fig. 28.

It should be noted that the position of C_{16} has been altered, so that the whole of the feedback network is at earth potential. This avoids switching transients which would otherwise occur, due to charging and discharging of capacitors as the switch is operated.

A small capacitor, C_{17} , has been connected across the input transformer secondary. This is to prevent any tendency to instability or peaking at high fre-

Fig. 26. Recording characteristic used for current Decca long-playing records.

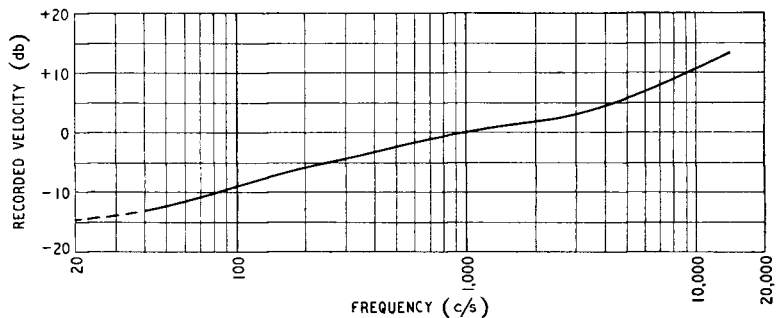



ADVANCED THEORY OF WAVEGUIDES By L. Lewin. Sets out the various methods that have been found successful in treating the types of problems arising in waveguide work.

30s. net. By post 30s. 7d.

RADIO DESIGNER'S HANDBOOK 4th Edition. Editor: F. Langford-Smith, B.Sc., B.E., Senior Member I.R.E. (U.S.A.), A.M.I.E. (AUST.). A comprehensive reference book, the work of 10 authors and 23 collaborating engineers. Intended especially for those interested in the design and application of radio receivers or audio amplifiers; contains a vast amount of data in a readily accessible form.

In preparation. 42s. net. By post 43s. 6d.

FOUNDATIONS OF WIRELESS 5th Edition. By M. G. Scroggie, B.Sc., M.I.E.E. Covers the whole basic theory of radio, the reader requiring no previous technical knowledge.

12s. 6d. net. By post 13s.

GUIDE TO BROADCASTING STATIONS 6th Edition. Compiled by "Wireless World." Tabulates, both geographically and in order of frequency, all European long-wave and medium-wave stations and 1,400 short-wave transmitters throughout the world.

2s. net. By post 2s. 2d.

HIGH-QUALITY AUDIO AMPLIFIERS

Popular circuits reprinted from "Wireless World." Includes "Wireless World A.C./D.C. Quality Amplifier," "High-Quality Amplifier Design" and "Economical 50-watt Amplifier."

2s. 6d. net. By post 2s. 8d.

MICROPHONES By the Staff of the Engineering Training Dept., B.B.C. Originally written as a textbook for B.B.C. engineers. Discusses the theory of the subject and describes the various microphones used in B.B.C. studios.

15s. net. By post 15s. 5d.

RADIO CIRCUITS: STEP-BY-STEP SURVEY OF SUPERHET RECEIVERS. 3rd Edition. By W. E. Miller, M.A. (CANTAB), M.BRIT.I.R.E. A simple explanation of the modern superheterodyne receiver.

5s. net. By post 5s. 4d.

RADIO DATA CHARTS 5th Edition. By R. T. Beatty, M.A., B.E., D.SC. Revised by J. McG. Sowerby, B.A., M.I.E.E. A series of Abacs providing graphical aid to most of the calculations required in receiver design.

7s. 6d. net. By post 7s. 11d.

RADIO LABORATORY HANDBOOK 5th Edition. By M. G. Scroggie, B.Sc., M.I.E.E. Describes methods of carrying out tests and measurements, using either commercial instruments or improvised equipment.

15s. net. By post 15s. 5d.

RADIO INTERFERENCE SUPPRESSION: AS APPLIED TO RADIO AND TELEVISION RECEPTION. 2nd Edition. By G. L. Stephens, A.M.I.E.E. Explains the principles of suppression technique as applied to both radio and television reception and gives many examples of practical applications.

10s. 6d. net. By post 10s. 11d.

SHORT-WAVE RADIO AND THE IONOSPHERE 2nd Edition. By T. W. Bennington. Shows how existing ionospheric data can be applied to everyday problems of short-wave transmission and reception.

10s. 6d. net. By post 10s. 10d.

SOUND RECORDING AND REPRODUCTION By the Staff of the Engineering Training Dept., B.B.C. Covers the theory and practice of disc, magnetic and film recording, with special reference to B.B.C. equipment.

30s. net. By post 30s. 8d.

TELEVISION ENGINEERING: PRINCIPLES AND PRACTICE. Volume 1: Fundamentals, Camera Tubes, Television Optics, Electron Optics. A B.B.C. Engineering Training Manual, by S. W. Amos, B.Sc., A.M.I.E.E., and D. C. Birkinshaw, M.B.E., M.A., M.I.E.E., in collaboration with J. L. Bliss, A.M.I.E.E. The first volume of a comprehensive work on the fundamentals of television theory and practice.

In preparation.

TELEVISION EXPLAINED 4th Edition. By W. E. Miller, M.A. (CANTAB), M.BRIT.I.R.E. A non-mathematical, step-by-step description of television reception circuits, aerials and aerial systems, receiver installation and operation.

5s. net. By post 5s. 4d.

TELEVISION RECEIVING EQUIPMENT 3rd Edition. By W. T. Cocking, M.I.E.E. A comprehensive explanation of the television receiver, including practical details, design data, special circuits and faults and servicing.

18s. net. By post 18s. 8d.

LEARNING MORSE 12th Edition. A guide to mastering the international signal code. Also gives details of an easily constructed morse practice set.

1s. net. By post 1s. 2d.

WIRELESS DIRECTION FINDING 4th (Revised) Edition. By R. Keen, B.ENG. (HONS.), A.M.I.E.E. Treats the subject historically, descriptively and with a wide range of bibliographical references. Includes much detail on the latest developments.

45s. net. By post 46s. 1d.

WIRELESS SERVICING MANUAL 8th Edition. By W. T. Cocking, M.I.E.E. A reliable guide for both amateur and professional. Describes testing methods and apparatus and the process of deducing and remedying defects.

12s. 6d. net. By post 12s. 11d.

Obtainable from all booksellers or direct by post from the address below. Complete list of titles sent on application.

ILIFFE & SONS LTD., DORSET HOUSE, STAMFORD ST., LONDON, S.E.1

The Williamson Amplifier

quencies, caused by the presence in the feedback loop of the stray secondary reactances of the transformer. The necessity for this capacitor and its minimum value will vary with the individual transformers. Its value should be kept as small as possible, consistent with stability.

Modifications to the three-stage high-pass pre-amplifier (original circuit Fig. 15, p. 26) are on the same lines, and Fig. 29 shows the revised circuit.

With these pre-amplifier circuits, the wiring to the selector switch must be kept short, and the switch should, if possible, be mounted on the pre-amplifier. Should the position of the pre-amplifier render such

a switch inaccessible, consideration should be given to the use of a relay in place of the selector switch, rather than the use of extension leads. This has the additional advantage that it could easily be operated from the speed-change lever by means of a micro-switch or from the additional switched pin which is a feature of some pickups with interchangeable heads.

Pickups without Transformers.—A number of pickups are available which do not normally require a transformer. It is possible to use the majority of these with the pre-amplifier circuits, by interposing a suitable 1:1 transformer. In other cases, when the connecting leads are short, it may be practicable to connect the pickup directly in place of the transformer secondary. The limiting factor will be the capacitance between the leads and their screening, which will be shunted across R_{31} or R_{64} , and which, if sufficiently large, would upset the treble compensation. The value of this stray capacitance should not be allowed to exceed 50 pF, and if C_{15} or C_{35} is switched out, should be compensated by a capacitance of one tenth of its value in parallel with R_{33} or R_{63} , to give a linear frequency-response characteristic at high frequencies.

Resistors R_{27} and R_{33} must be

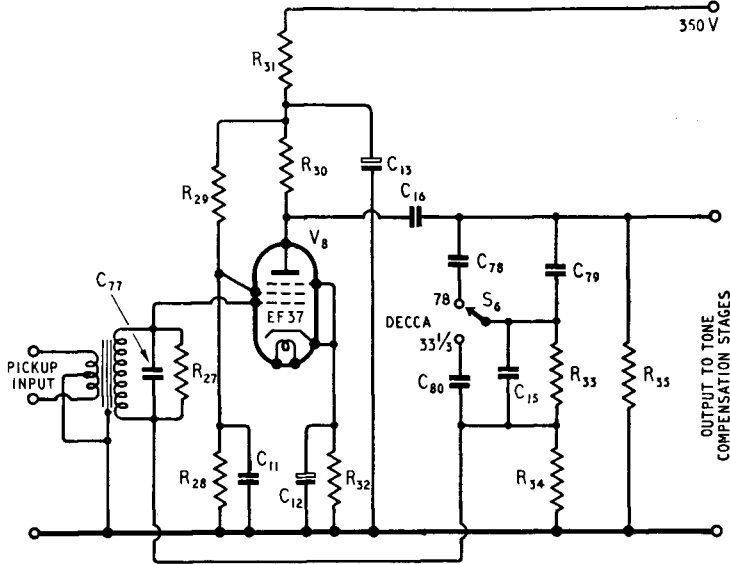

Left : Fig. 27. Simple two-position switching in single-valve pre-amplifier for playing Decca 78-r.p.m. standard and 33½-r.p.m. L.P. records. Compensation for the E.M.I. 78-r.p.m. standard characteristic should be applied separately by the treble tone control.

List of Components for Fig. 27

Component	Value to suit	Type	Rating	Tolerance
R_{27}	Value to suit transformer	High-stability carbon		
R_{28}	0.1M Ω	do.	½W	
R_{29}	0.68M Ω	do.	½W	
R_{30}	0.22M Ω	do.	½W	
R_{31}	47k Ω	do.	½W	
R_{32}	4.7k Ω	do.		
R_{33}	0.22M Ω	Composition		10 %
R_{34}	22k Ω	do.		10 %
R_{35}	2.2M Ω	do.		

All resistors may be ½W rating, tolerance 20% unless otherwise specified.

Component	Value	Type	Rating (V d.c. working)	Tolerance
C_{11}	0.5 μ F	Paper	250	
C_{12}	50 μ F	Electrolytic	12	
C_{13}	16 μ F	do.	450	
C_{15}	100pF	Silvered mica	250	10 %
C_{16}	0.05 μ F	Paper	500	
C_{77}	10–50pF	Silvered mica	250	
C_{78}	2500pF	do.	250	10 %
C_{79}	1500pF	do.	250	10 %
C_{80}	300pF	do.	250	10 %
S_6	Single-pole changeover switch			

Below : Fig. 28. Alternative circuit (applicable to Figs. 27, 29 and 30) with three-position switch giving compensation for Decca 33½, Decca 78 and E.M.I. 78-r.p.m. recording characteristics.

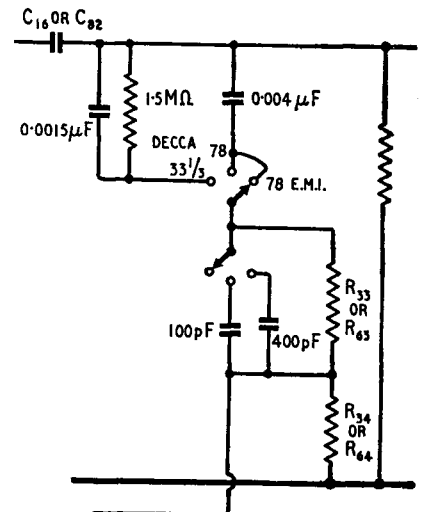

HANNEY OF BATH

WILLIAMSON AMPLIFIER COMPONENTS

12 1% silver mica condensers for fig. 19	15 0
7 5% silver mica condensers for fig. 19	7 0
25 Resistors and pots for Williamson main amplifier.....	33 9
9 Resistors for fig. 13.....	9 6
23 Resistors for fig. 15.....	24 0
22 Resistors and pots for fig. 19....	37 0
6 Condensers for fig. 13.....	15 0
15 Condensers for fig. 15.....	47 0
33 Condensers for fig. 19.....	54 6
10 Resistors for fig. 20.....	6 8
7 Condensers for fig. 20 (less C68 and C72)	12 9
Matched pair of 47 K 2watt resistors	4 0
Matched pair of 22K 1½ watt resistors	2 8
5 Bank 6 position switch.....	9 6
S.P.D.T. genuine OAK switches....	4 4
D.P.D.T. genuine OAK switches....	4 8
Reliance 100 ohm potentiometers	5 6

Small quantities of **WODEN** mains transformers, chokes and output transformers are available from time to time, as detailed in our current list supplement.

T.C.C. .25 mfd. metalpacks (coupling condensers for fig. 1) each	2 10
T.C.C. .05 mfd. metalmites (coupling condensers for fig. 1) each	2 1
KT 66 valves, matched pair, including tax	50 2
EF37A valves (EF37 now obsolete) (including tax)	25 1
Mains transformer to specification 10 henry 150 mA choke to specification	57 6
30 henry 20 mA choke to specification	20 0
Williamson output transformers by ELSTONE (3.6 ohm secondary).....	10 0
	90 0

PARTRIDGE type WWFB/0/1.7 output transformers unpotted, including packing	127 0
Acos GP 20 pickups, standard or LP	71 5
Heads only, standard or LP.....	43 4
B.S.R. type GU4 gram-motors.....	£9 19 6
B.S.R. type MUI4 3 speed motors	£7 3 4
B.S.R. type MUI0 2 speed motors	£3 14 4
COLLARO type 3RC521 auto-changers, 3 speed unmixd, with 2 Hi-Fi crystal heads.....	£18 14 8
COLLARO type 3RC522 auto-changers, as above but plays 10 and 12 inch records MIXED	£21 4 3
CHANCERY LP attachment, converts 78 r.p.m. motor to LP in a matter of seconds	72 6
GOODMANS AXIOM 150 speakers	£10 5 6
GOODMANS AUDIOM 60 speakers	£8 12 6
ROLA G12 speakers.....	£8 5 0

The above is only a selection of our large stocks, send 6d. stamp now for our current list and supplement, and save yourself time and trouble.

L. F. HANNEY
77 LOWER BRISTOL ROAD, BATH
 Telephone : 3811

RADIO DESIGNER'S HANDBOOK

A comprehensive reference, the work of
 10 authors and 23 collaborating engineers

Previous editions of Radio Designer's Handbook have achieved exceptional success, many thousands of copies of this standard reference work having been sold in all parts of the world. The book deals with general theory, components, testing and design. The new edition is more than four times as large as the previous volume, and contains work hitherto unpublished. It is the work of ten authors and twenty-three collaborating engineers, under the editorship of F. Langford-Smith. The work is intended for those

especially interested in the design and application of radio receivers or audio amplifiers; it contains an enormous amount of data which has been made readily accessible by means of a fully-detailed list of contents and a comprehensive index.

The main subjects are: valves and valve testing, general theory and components, audio frequencies, radio frequencies, power supplies, design of complete A-M and F-M receivers, and reference data.

Publication May, 1953. 42s. net. By post 43s. 6d.

Obtainable from all booksellers or direct by post from the address below.

ILIFFE & SONS LTD., DORSET HOUSE, STAMFORD ST., LONDON S.E.1

The Williamson Amplifier

retained to provide a conducting path to the valve grid when the pickup heads are being interchanged.

There may be cases, where one side of the input must be earthed, in which it is impracticable to utilize the pre-amplifiers in this way. In this event the circuit may be modified as shown in Fig. 30. This circuit applies to both pre-amplifiers. In it, the transformer had been replaced by a resistive network R_{96} , R_{97} , mixing the input and feedback voltages.

The input resistance of this circuit is approximately 0.1 M Ω , and its voltage gain at 1,000 c/s is 9. The frequency-response curve is almost identical with that

of Fig. 14, p. 25. This circuit is suitable for most moving-iron variable-reluctance pickups, and can be used with piezoelectric pickups which have been loaded to give an output proportional to recorded velocity.

Danger of Overloading.—The input to the pre-amplifiers should be restricted to 200 mV in the case of the single-stage circuits and 50 mV for the three-stage circuit, and if necessary a potential divider should be used.

Piezoelectric Pickups.—Lightweight piezoelectric pickups have recently become popular, particularly for L.P. recordings. Since these give a relatively high output, no pre-amplifier is necessary and any correction required may be achieved by means of simple

Below : Fig. 29. Revised three-stage pre-amplifier circuit with high-pass filter, to play Decca 33 $\frac{1}{2}$ and 78-r.p.m. records.

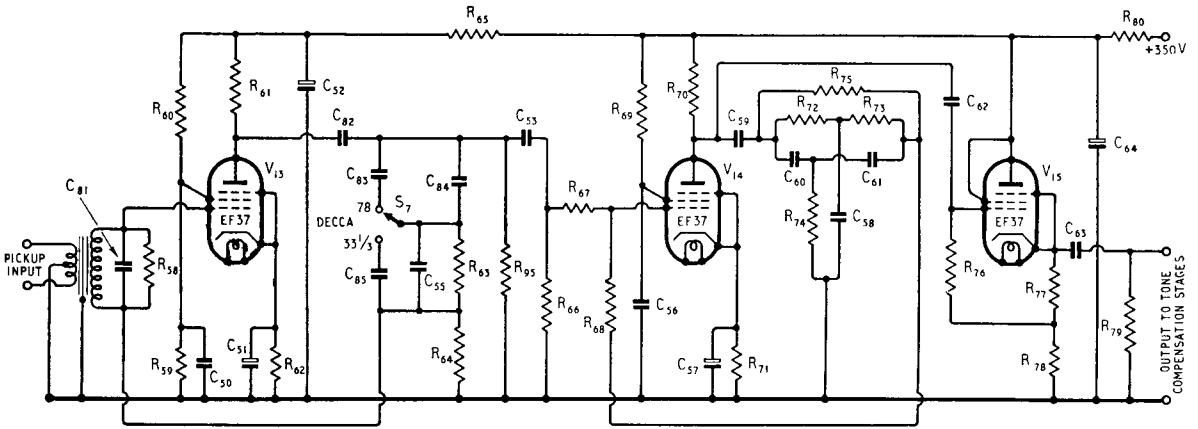

Component Values for Circuit of Fig. 29

Resistor	Value	Type	Rating	Tolerance	Capacitor	Value	Type	Rating (V d.c. working)	Tolerance
R_{58}	Value to suit Transformer	High-stability Carbon			C_{50}	0.5 μ F	Paper	250	20%
R_{59}	0.1M Ω	do.	$\frac{1}{2}$ W	20%	C_{51}	50 μ F	Electrolytic	12	
R_{60}	0.68M Ω	do.	$\frac{1}{2}$ W	20%	C_{52}	16 μ F	do.	450	
R_{61}	0.22M Ω	do.	$\frac{1}{2}$ W	20%	C_{53}	0.02 μ F	Paper	350	10%
R_{62}	4.7k Ω	do.		20%	C_{55}	100pF	Silvered mica	350	10%
R_{63}	0.22M Ω	Composition		10%	C_{56}	0.5 μ F	Paper	250	20%
R_{64}	20k Ω *	do.			C_{57}	50 μ F	Electrolytic	12	
R_{65}	22k Ω	High-stability carbon	$\frac{1}{2}$ W	20%	C_{58}	0.01 μ F	Silvered mica	350	1%
R_{66}	0.22M Ω	Composition		10%					or matched
R_{67}	0.20M Ω *	do.			C_{59}	0.25 μ F	Paper	500	20%
R_{68}	4.7M Ω	do.		5%	C_{60}	5000pF	Silvered	350	1%
R_{69}	1.0M Ω	do.	$\frac{1}{2}$ W	20%					or matched
R_{70}	0.22M Ω	do.	$\frac{1}{2}$ W	20%	C_{61}	5000pF	do.	350	do.
R_{71}	2.2k Ω	do.		20%	C_{62}	7000pF	do.	350	10%
R_{72}	2.0M Ω	High-stability carbon		1% or matched	C_{63}	0.5 μ F	Paper	500	20%
R_{73}	2.0M Ω	do.		do.	C_{64}	16 μ F	Electrolytic	450	
R_{74}	1.0M Ω	do.		do.	C_{81}	10-50pF	Silvered mica	250	
R_{75}	10M Ω	Composition		5%	C_{82}	0.1 μ F	Paper	500	
R_{76}	47k Ω	do.		10%	C_{83}	2500pF	Silvered mica	250	10%
R_{77}	1k Ω	do.		20%	C_{84}	1500pF	do.	250	10%
R_{78}	47k Ω	do.	1W	20%	C_{85}	300pF	do.	250	10%
R_{79}	0.22M Ω	do.		20%	S_7	Single-pole changeover switch.			
R_{80}	10k Ω	do.	1W	20%					
R_{95}	2.2M Ω	do.		20%					

* May require adjustment.

All resistors may be $\frac{1}{2}$ W rating, except where otherwise stated.

The Williamson Amplifier

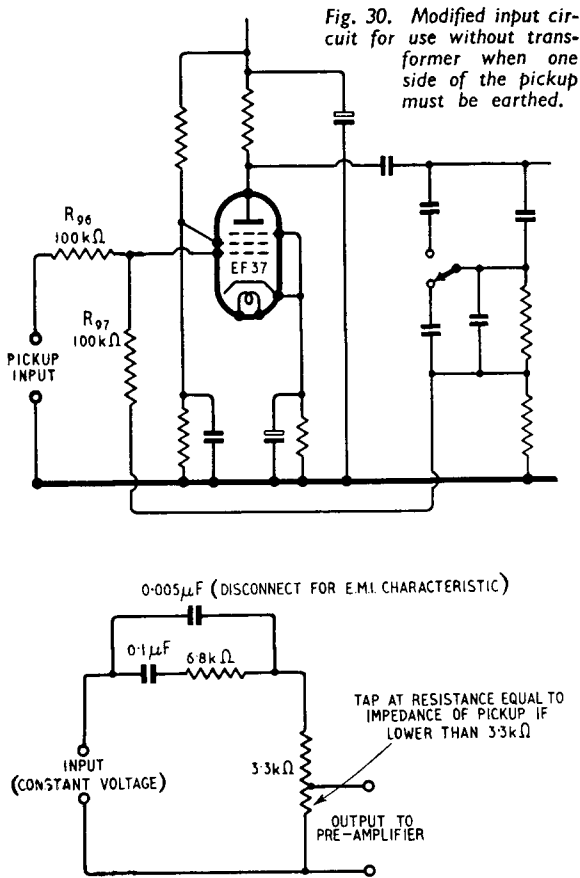

Fig. 31. Simulator for Decca and E.M.I. 78-r.p.m. recording characteristics.

RC networks, details of which have already been published.¹

Checking the Pre-amplifiers.—When a pre-amplifier has been constructed, it is advisable to measure its response curve over the audible frequency range and beyond, in order to ensure that nothing is amiss. This is particularly so in the case of the three-stage pre-amplifier.

To facilitate this measurement the networks of Figs. 31 and 32 have been devised. These circuits, when fed with constant-voltage variable-frequency input,

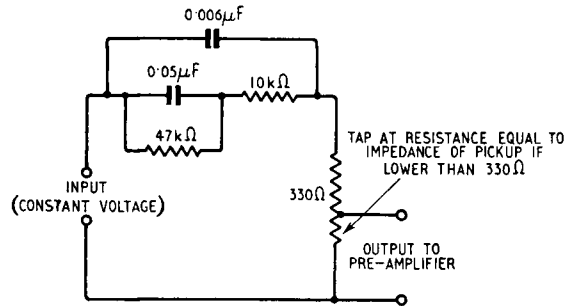

Fig. 32. Simulator for Decca 33½ r.p.m. L.P. characteristic.

produce outputs which are, respectively, replicas of the standard and L.P. characteristics.

To test a pre-amplifier, the appropriate network should be connected between an oscillator and the pre-amplifier input. The output from the pre-amplifier for a constant voltage to the network should then follow the response curve already published for the appropriate circuit (Figs. 14 and 17, pp. 25 and 27).

Acknowledgment.—The writer is indebted to Decca for information about their recording characteristic.

¹ West and Kelly, "Pickup Input Circuits," *Wireless World*, November, 1950, pp. 386-391.

GOODSELL

WILLIAMSON HIGH-FIDELITY AMPLIFIERS

- ★ The Goodsell version of the World famous Williamson Amplifier is to full specification, laboratory built and tested.
- ★ All components are adequately rated to ensure long life and trouble free operation.
- ★ Fully tropicalized version, Type GW18/C is available for use overseas.
- ★ All models have separate power supply incorporated on the same chassis for use with multi-stage pre-amplifiers, tape pre-amplifiers and tuner units.



A laboratory report of a Williamson Amplifier, our type GW18/C, which was submitted to intermodulation tests. The results using an Altec Lansing Intermodulation Distortion Meter and Boonton Beat Frequency Oscillator are given.

The report on the Goodsell pre-amplifier showed it to be a comparable unit with similar figures.

Type GW18 (standard model) Price £33 : 5 : 0

Type GW18/C (as illustrated) Price £36 : 0 : 0

I.M. Distortion	Power Output	Frequency Ratio 1 : 4
2%	15 watts	40 & 2,000 c/s.
0.3%	10 watts	40 & 2,000 c/s.
0.9%	15 watts	100 & 2,000 c/s.
0.2%	10 watts	100 & 2,000 c/s.

PRE-AMPLIFIER TONE CONTROL UNITS

Multi-stage, low noise tone control units with radio input and gramophone pre-amplifier. Equalization for micro-groove and standard recording characteristics, 5 position steep cut low-pass filter and cathode follower out-put. Feedback over every stage ensures negligible distortion.

Type PFA with equalization for British and American recording characteristics and 5 mv sensitivity on LP and 78. Price £22 : 10 : 0

Type FUTC with LP and 78 equalization and 15 mv sensitivity. Price £12 : 12 : 0

MANUFACTURED BY—

GOODSELL LTD., 40, GARDNER STREET, BRIGHTON, 1

Phone : Brighton 26735



VALVES *for the* WILLIAMSON AMPLIFIER

The following Osram valves are specified :
L.63, *B.65, KT.66, U.52.

Use of KT.66 is essential to obtain optimum performance of this equipment.

The characteristics of KT.66 and 6L6G are not identical.

Circuit information on a Quality Amplifier for DC/AC operation may be obtained from the Osram Valves & Electronic Dept., Magnet House, Kingsway, W.C.2.

**B.65 double triode as alternative for any two L.63 type.*



L.63



KT.66



B.65



U.52

THE GENERAL ELECTRIC CO., LTD., MAGNET HOUSE,



KINGSWAY, W.C.2

MODERNIZE

your WILLIAMSON

by

David Hafler

Dyna Company

REPRINTED FROM AUDIOCRAFT, JANUARY 1956

Modernization of Williamson-type amplifiers can be readily accomplished by use of new components and circuit modifications. These changes improve performance by increasing power handling capabilities and extending the margin of stability. This article describes the modernization procedure for a popular circuit using the new Dynaco A-430 transformer and EL-34 output tubes.

DYNA COMPANY

DYNACO

5142 MASTER STREET
PHILADELPHIA 31, PA.

MODERNIZE your Williamson Amplifier

by DAVID HAFLER

THE Williamson amplifier circuit was first publicized in England in 1947, and in this country in 1949. It has achieved wide acceptance and popularity, and has been the basis for several modifications of the original design. The most basic change was the ultra-linear version of operation, which I developed and subsequently described*. This arrangement corrected 2 of the basic deficiencies in the original design—it increased the power capability of the amplifier to 25 or 30 watts, and it improved the margin of feedback stability.

Now, as always happens, progress in amplifier design has continued: it is possible to make further improvements in the Williamson design (both triode and ultra-linear versions). These improvements again correct for limitations with respect to power output and stability.

Increasing Power Output

Present thinking on requirements for audio power is vastly different from that of a few years ago. Then, most people said, "Ten watts is enough for me." Now, however, modern program material has been increased in dynamic range many times over that of former years. This fact alone has increased the power requirements substantially for realistic, undistorted reproduction. In addition, source material frequency response has been extended, and this also introduces the need for a re-evaluation of amplifier power requirements. Increased frequency response means that the amplifier has to handle power at greater extremes of frequency. At these extremes, the impedance characteristics of the loudspeaker change from the nominal values. This means that the amplifier is *mismatched* at frequency extremes, and a mismatch decreases the maximum-power capabilities of any amplifier.

To deliver clean power into a loudspeaker load, an amplifier must be capable of at least *twice* the power required for a resistor load such as is used in measuring and rating amplifiers. Thus the extension of both dynamic range and frequency range in modern recordings, FM sources, and tape means that 25 watts are about a *minimum* if top-grade

performance is required. Even this minimum will probably be increased in the years to come unless the efficiency of loudspeaker systems can be increased.

For these and related reasons, efforts have been devoted to increasing the power output of audio amplifiers. The advent of some new tube types has made this practical within the Williamson configuration without the need for completely rebuilding the amplifier. Changes required are replacement of the output tubes, substitution of an output transformer which will handle the increased power and provide suitable impedance matching, and addition of fixed bias.

New Output Tubes

The new tube selected for modernization of the Williamson is the Amperex 6CA7, which is also imported and distributed as the Mullard EL-34. This is a compact tube with power capabilities up to 100 watts, depending on the supply voltages available. It can be plugged directly into the sockets formerly used for 5881's, KT66's, 1614's, and other tubes of this type, with the single additional requirement that the No. 1 pins must be grounded.

The 6CA7/EL-34 is a pentode tube

of extreme linearity. Its preferred operating condition is as a pentode: although the manufacturer furnishes triode ratings for the tube, triode operation results in higher distortion and reduced power output. The conventional ultra-linear connection cannot provide optimum results with these tubes either, since there is no type of operation more linear than the pentode connection for which they were designed. As will be discussed later, however, a compromise form of operation fits the needs of the Williamson modernization very nicely.

To derive the potential benefits available in these tubes, proper impedance matching must be obtained in the output transformer. The Dynaco A-430 transformer has been designed specifically for this purpose. This is a 50-watt unit, the performance of which exceeds Mr. Williamson's specifications with respect to frequency response, permissible feedback, power handling ability, and so on. At present this is the only commercial transformer of correct impedance, but it is anticipated that others may be available soon.

The Dynaco A-430 has primary taps which can be used to furnish about 10% screen loading. This does not cause de-

Fig. 1. Complete circuit diagram of a Williamson amplifier modified as described.

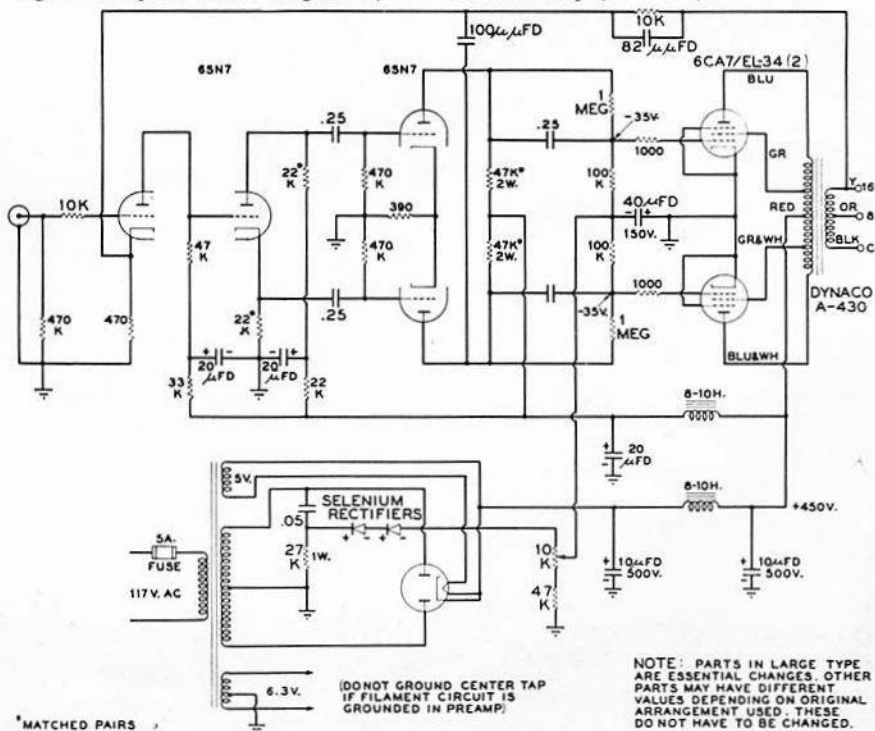

*Hafler, D., and Keroes, H. I., "Improving the Williamson Amplifier", Radio & Television News, February 1953.

THE FINEST COMPONENTS

All premium components are used in the DYNAKIT to insure permanence of characteristics without failures and to provide neat clean appearance. Some of these "extra" features which are normally only available in custom built equipment are:

- DYNACO A-430 output transformer. This unit sells separately from the kit for \$29.95 net. It is the finest of its type
- A heavy duty, conservatively rated power transformer with capacity to power a pre-amplifier if desired
- Ceramic cased and plastic paper capacitors
- 500 volt specially formed electrolytic capacitor
- 1000 volt mica capacitor
- Dependable highly linear EL-34/6CA7 tubes
- Heavy duty rectifier tube
- XXXP etched circuit board with parts mounted and dip soldered. Metal eyelets for external connections to eliminate strain on plated wiring.
- Underwriter approved line cord
- On-off switch
- "Wired in" fuse
- Bias setting control
- Nickel plated, binder (flat) head screws
- High temperature insulation, solid hookup wire
- Spot welded heavy gauge chassis
- Protective cover and bottom plate
- Spare socket for pre-amp power, remote on-off switching, etc.

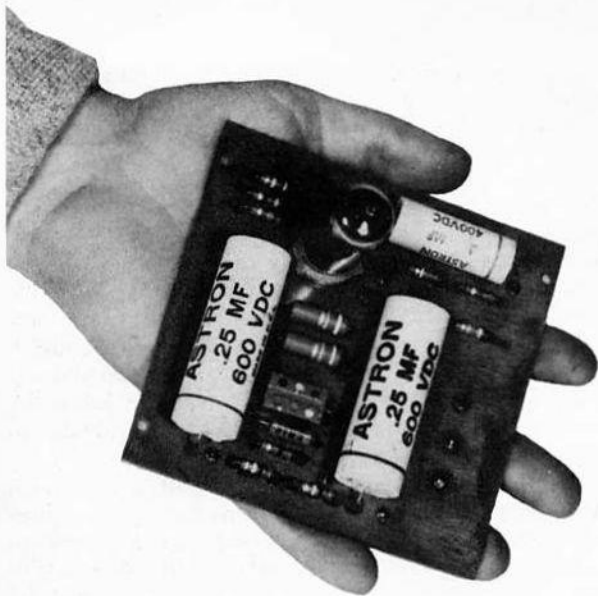

THE EASIEST TO ASSEMBLE

The use of the pre-assembled printed circuit board eliminates two-thirds of the work. An inexperienced constructor can figure on about three hours of enjoyable and interesting assembly time in mounting parts and soldering the connections. The work is simplified by detailed point-by-point instructions included with the DYNAKIT and by two-step pictorial diagrams which show the placement of every lead and every part.

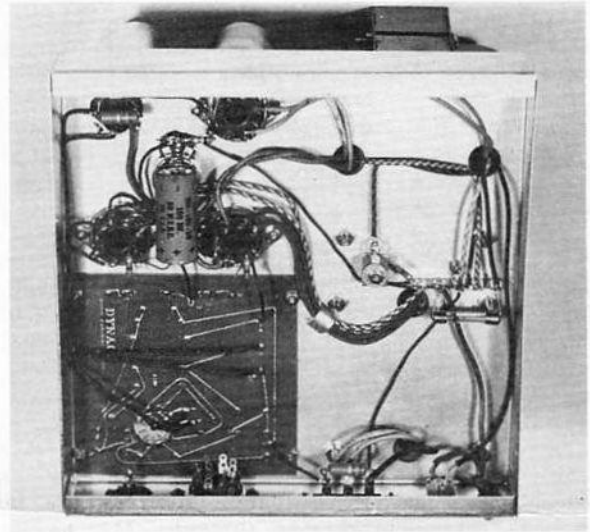

THE DYNAKIT'S PERFORMANCE

The measured specifications show that the DYNAKIT rates with the very best of amplifier equipment in the highest price brackets. What these specifications cannot show, however, is how the DYNAKIT amplifier sounds. The clarity, crispness, and smoothness that are attained because of its low distortion, high stability, and superior transient response can only be described through demonstration and comparison with other equipment.

The person who uses a DYNAKIT amplifier will find that familiar music has less stridency and harshness at high frequencies and less muffled quality in the lower frequency passages.

Percussive sounds will have more "snap" while strings will have a more natural sheen. Distortion which was formerly attributed to record breakup or to speaker overload will vanish when the 50 watt DYNAKIT replaces a lower powered amplifier. The advantage of the large power reserve shows up most readily in reproducing large choral works and massive string ensembles, and yet even solo instruments will be reproduced more naturally because of the performance attributes of the DYNAKIT amplifier. We believe that the DYNAKIT Mark II provides listening quality unequalled by any amplifier regardless of price, size, or degree of complexity.

stability are important design problems.

By these standards, then, original Williamson amplifiers have inadequate stability at both extreme low and high frequencies. This can be demonstrated for the low end by touching the input grid momentarily with the fingertip and watching the speaker cone. The heavy low-frequency transient which is generated triggers the amplifier, and there are usually several surges before the effect is damped out. The speaker cone can be observed to move back and forth several times before coming to rest. This means that short signal impulses will also cause spurious cone movements which tend to blur the sound.

At high frequencies, the corresponding effect can be viewed on an oscilloscope with a square-wave signal input. A rippled square wave is indicative of basic instability, and indicates that there is a transient distortion of high-frequency signals.

Instability is due to the fact that the phase characteristics of the amplifier cause some of the feedback to be applied *positively* instead of *negatively* at the frequency extremes. The remedy is superficially simple—to shift the phase in the right direction at the critical frequencies. It is not always simple to do this. Fortunately, the phase characteristics of the A-430 transformer and the Williamson circuit arrangement permit complete correction of the low-frequency phase characteristic and appreciable correction of the high-frequency characteristic. These corrections are made with a few inexpensive components.

The low-frequency correction is achieved by shunting the $0.25\text{-}\mu\text{fd}$ coupling capacitors which go to the output grids with 1 megohm resistors. High-frequency correction is obtained with a $100\text{-}\mu\text{fd}$ capacitor which is connected from the lower driver plate to the cathode of the first stage. Without going into the theory underlying these corrections, it is worth mentioning that they have a tremendous effect on performance. (It is assumed that the 10,000-ohm resistor in the input grid, change of the $.05\text{-}\mu\text{fd}$ capacitors to 0.25, and the use of a small capacitor across the feedback resistor as indicated in the schematic are already included in the amplifier. If not, these should also be added in accordance with previous recommendations*.)

This completes the modernization of the Williamson. If the power supply puts out a full 450 volts with reasonable regulation, the output power will be about 50 watts at 1% IM distortion. If the power supply provides lower voltage, the output power will be reduced somewhat. Below full output, the distortion drops

rapidly toward a vanishing point. The frequency response of the amplifier will be approximately the same as that of the original version except that peaks in the response (associated with instability) are eliminated. The transient response—that unmeasurable intangible—will be audibly better. It will be particularly evident in more solid, better-defined bass and smoother, cleaner treble.

Appendix

The following specific hints will be helpful to those who are interested in modernizing the Heathkit W-3M Williamson:

The bias voltage divider and rectifier can go in the power supply chassis. Output of the selenium rectifier is connected to pin 5 of the power socket and carried through the spare wire in the connecting cable to one side of the 10,000-ohm bias-setting pot.

The 250-ohm and two 100-ohm resistors are discarded, as is the 100-ohm pot. The bias pot replaces the 100-ohm balance adjustment, and the blank tie points to which the 100-ohm resistors were fastened can then be used to connect leads which are part of the ground circuit.

In the interests of economy, the $20\text{-}\mu\text{fd}$ capacitor which formerly by-



passed the cathodes can be used for filtering the bias supply. The schematic calls for $40\text{ }\mu\text{fd}$, but the difference in hum level is only 2 db.

Jacks formerly used for metering plate current can still be used to check equality of the output tubes. The former connection to the 250-ohm bias resistor must now be grounded in order to complete the circuit path for the cathode current. At the same time the No. 1 pins (suppressor grids of the output tubes) should be connected at the socket to the No. 8 (cathode) pins.

In order to insert the 10,000-ohm parasitic suppressor resistor directly at the input grid, the 2.2-megohm resistor should be reconnected directly from the input socket to ground. The 10,000-ohm resistor can then be inserted from the input connector to pin 1 of the first 6SN7 tube. This replaces the $.05\text{-}\mu\text{fd}$ capacitor which is used as part of the bias supply in the power chassis. Make sure that the preamplifier used has an output coupling capacitor since the amplifier now has none in the input. Practically all preamplifiers are so

equipped; if not, one should be added.

The $.05\text{-}\mu\text{fd}$ coupling capacitors between the two 6SN7's should be increased to $0.25\text{ }\mu\text{fd}$. Care should be exercised in order to get these to fit the space. If difficulty is encountered, it is suggested that miniature capacitors be used, such as Aerolites made by Aerovox.

The 1-megohm phase-correcting resistors across the coupling capacitors permit some positive DC to appear on the grids if the negative bias supply is inoperative. The existence of negative voltage at the grid should be checked with the rectifier removed before permitting the B+ voltage to be applied. Then the rectifier should be inserted and the bias set to 35 volts from grid to ground *after* the tubes have had time to warm up. Do not remove the second 6SN7 while the amplifier is on, because this will cause additional positive voltage to be applied to the grids of the output stage, upsetting the bias and possibly harming the tubes.

AUDIOCRAFT Test Results

The amplifier shown in Figs. 2 and 3, which was the basic Williamson converted in accordance with this article, produced 0.6% IM distortion at 50 watts output, 0.2% at 36 watts, and 0.1% at 15 watts. Below 15 watts distortion was in the residual range of the meter and could reasonably be called negligible if not unmeasurable. Test frequencies were 60 and 7,000 cps, mixed in a 4-to-1 ratio.

These readings could have been improved slightly by using parts matched more precisely, or by adding to the power supply filtering. It is doubtful that such small improvement would be apparent audibly. On the other hand, if the phase inverter balance were off, or certain other elements had drifted in value, the distortion figures might be doubled—still exceptionally good performance.

Frequency response was perfectly flat within the range of our test equipment. Calculated response, without the $100\text{-}\mu\text{fd}$ feedback capacitor at the driver stage plate, is ± 1 db from 2 to 200,000 cps; with this added, response above 80,000 cps slopes off smoothly. This capacitor causes a very slight increase in distortion at 20,000 cps, which is quite insignificant compared to the 12 db increase in the high-frequency stability margin. Stability at the low end, determined by recovery characteristics from a sharp overload pulse, was apparently perfect.

Square-wave response at low frequencies was excellent, and exceptionally good at high frequencies. Power response was completely flat from 20 to 20,000 cps at 50 watts. Total cost for all parts required to make the complete conversion: less than \$40.00.

*Hafner, D., "A 60 Watt Ultra-Linear Amplifier", Radio & Television News, February 1955.